



WindMaster
(Part 1590-PK-020)
&
WindMaster Pro
(Part 1561-PK-020)
Ultrasonic Anemometer

User Manual

Doc No. 1561-PS-0001

Issue 06

Gill Instruments Limited

Saltmarsh Park,
67 Gosport Street,
Lymington,
Hampshire,
SO41 9EG
UK

Tel: +44 (0) 1590 613500

Fax: +44 (0) 1590 613501

陕西威瑞仪器仪表有限公司 生产代理销售：实验检测设备气象科学仪器设备

Tel:18966887800 Web:www.xavery.cn Email:verytrade@163.com

Contents

Contents	2
1. FOREWORD	4
2. INTRODUCTION	4
3. PRINCIPLE OF OPERATION	5
Polar definition	6
U, V, and W axes definition	6
Effects of temperature, barometric pressure, rainfall and humidity	6
Effects of temperature, barometric pressure, rainfall and humidity	7
Measurement sequence	7
Signal processing	7
4. SPECIFICATION	8
5. PRE-INSTALLATION	9
5.1. Equipment supplied	9
5.2. Software	9
5.3. Options	9
5.4. Accessories	9
5.5. Packaging	9
5.6. Installation requirements	9
PC requirement	9
Other equipment	10
Connection	10
Power supply	10
6. INSTALLATION	11
6.1. Installation Guidelines	11
6.2. Bench system test	11
6.3. Cable type	11
6.4. Cable length	12
6.5. Connections	13
Cable assembly	14
Connector Pin & Conductor positions	15
Grounding (Earthing)	17
6.6. Connection to a PC using RS 232	18
6.7. Connection to a PC using RS 422	18
6.8. Connection to a PC via a Power and Communications Interface	19
Environmental	19
PCI Electrical Power Requirements	19
Connector Pin and Cable Assignments for PCI/A	20
PCIA Box WindMaster Analogue Output Connections.	20
6.9. Networking using RS485	22
6.10. Mechanical installation	23
Location	23
Orientation	23
Alignment and Dimensions	23
Corrosion	23
Grounding (Earthing)	23
Cable strain relief	24
Flange mounting	24
Pipe mount adaptor	24
7. MESSAGE FORMATS	25
7.1. Mode 1– ASCII, UVW, Continuous	25
WindMaster Identification node address	26
Horizontal wind speed	26
Vertical wind speed	26

Units	26
Speed of Sound (SOS)	26
Sonic temperature	26
Status	26
Analogue Inputs (Unit order option)	26
PRT (Unit order option)	26
Checksum	26
Output rate (not displayed)	26
7.2. Mode 2 – ASCII, Polar, Continuous (Default)	27
Horizontal wind direction	28
7.3. Mode 3 –ASCII, UVW, Polled.	28
7.4. Mode 4 –ASCII, Polar, Polled.	29
7.5. Mode 7 –Binary, Polar, Short	29
7.6. Mode 8 –Binary, UVW, Short	30
7.7. Mode 9 –Binary, Polar, Long	30
7.8. Mode 10 –Binary, UVW, Long	30
8. ANALOGUE INPUTS	32
8.1. Analogue Inputs	32
8.2. PRT input	32
8.3. Input Rates	32
9. ANALOGUE OUTPUTS	33
9.1. Output allocations	33
9.2. Output types	33
9.3. Voltage outputs	33
9.4. Current outputs	33
9.5. Scaling	33
9.6. Polar wind direction wraparound	33
9.7. Speed of Sound and Sonic Temperature	34
9.8. Status	34
10. CONFIGURING	35
10.1. WIND software	35
10.2. Configuring using HyperTerminal	39
Setting up	39
Entering Configuration mode	39
Returning to Measurement mode	39
Checking the configuration	39
Changing settings	40
Command List	40
11. MAINTENANCE & FAULT-FINDING	46
11.1. Cleaning	46
11.2. Servicing	46
11.3. Fault-finding	46
11.4. Status (error) codes	46
11.5. Returning unit	47
12. TESTS	47
12.1. Bench test	47
12.2. Calibration	47
Standard calibration	47
Certified calibration	47
13. APPENDICES	47
13.1. Guarantee	47
13.2 Electrical Conformity	48
EC DECLARATION OF CONFORMITY ACCORDING	48

1. FOREWORD

Thank you for purchasing a WindMaster or WindMaster Pro manufactured by Gill Instruments Ltd. The units have no customer serviceable parts and require no calibration or maintenance. To achieve optimum performance we recommend that you read the whole of this manual before proceeding with use.

Gill products are in continuous development and therefore specifications may be subject to change and design improvements without prior notice.

The information contained in this manual remains the property of Gill Instruments and should not be copied or reproduced for commercial gain.

2. INTRODUCTION

This manual describes the operation of both the WindMaster (1590-PK-020 + options) and WindMaster Pro (1561-PK-020 + options). The instruments replace the previous WindMaster model (1086-PK-046) and WindMaster Pro (1352-PK-001). Refer to appropriate manuals for these instruments.

The term 'WindMaster' is used in this manual as a general term for both the WindMaster and the WindMaster Pro; they are robust three axis anemometers, with no moving parts.

The units of wind speed, output rate, and formats are all user selectable.

The WindMaster, constructed in aluminium and carbon fibre, can perform measurements in wind speeds up to 45 m/s.

The WindMaster Pro, constructed from marine grade stainless steel 316, can perform measurements in wind speeds up to 65 m/s.

Options include up to four analogue input and four analogue output channels (12 or 14 bit resolution for WindMaster; 14 bit resolution for WindMaster Pro. A PRT input is also available (WindMaster Pro only).

Units may additionally be calibrated in a wind tunnel to ISO 16622, traceable to national standards.

WIND software is available free from the Gill website www.gill.co.uk. It is strongly recommended as it provides an easy, user-friendly interface.

3. PRINCIPLE OF OPERATION

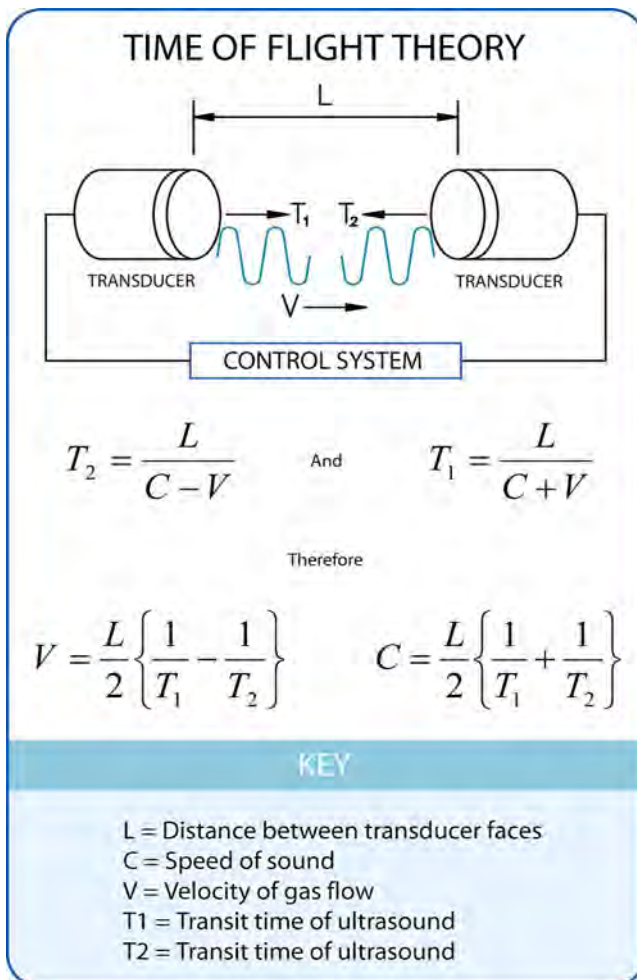

Figure 1 Time of Flight details

The WindMaster measures the times taken for an ultrasonic pulse of sound to travel from an upper transducer to the opposite lower transducer, and compares it with the time for a pulse to travel from lower to upper transducer.

Likewise times are compared between each of the other upper and lower transducers.

As Figure 1 shows, the air velocity along the axis between each pair of transducers can then be calculated from the times of flight on each axis.

This calculation is independent of factors such as temperature.

From the three axis velocities, the wind speed is calculated, as either signed U, V, and W, or as Polar and W.

It can be seen from Figure 1 that the speed of sound in air can be calculated from the times of flight. From this the sonic temperature can be derived from the formula $T_{S1} = C_1^2 / 403$

Where

T_{S1} = Sonic temperature

C_1 = Speed of sound

Note the formula does not account for the effect of Humidity

Figure 2 shows the direction and polarity of the U, V and W axes.

Polar definition

The wind speed in the UV plane, with direction in degrees from 0 to 359 °, with respect to the Reference spar (which is normally aligned to North).

U, V, and W axes definition

+U is defined as towards the direction in line with the north spar as indicated in the diagram.

+V is defined as towards the direction of 90° anti-clockwise from N / the Reference spar.

+W is defined as vertically up the mounting shaft.

Note, when the unit is configured for the X2 setting the UV definition rotates 30 degrees anti-clockwise such that U is now in line with transducer axis 1.

Figure 2 U, V and W Axis Definition

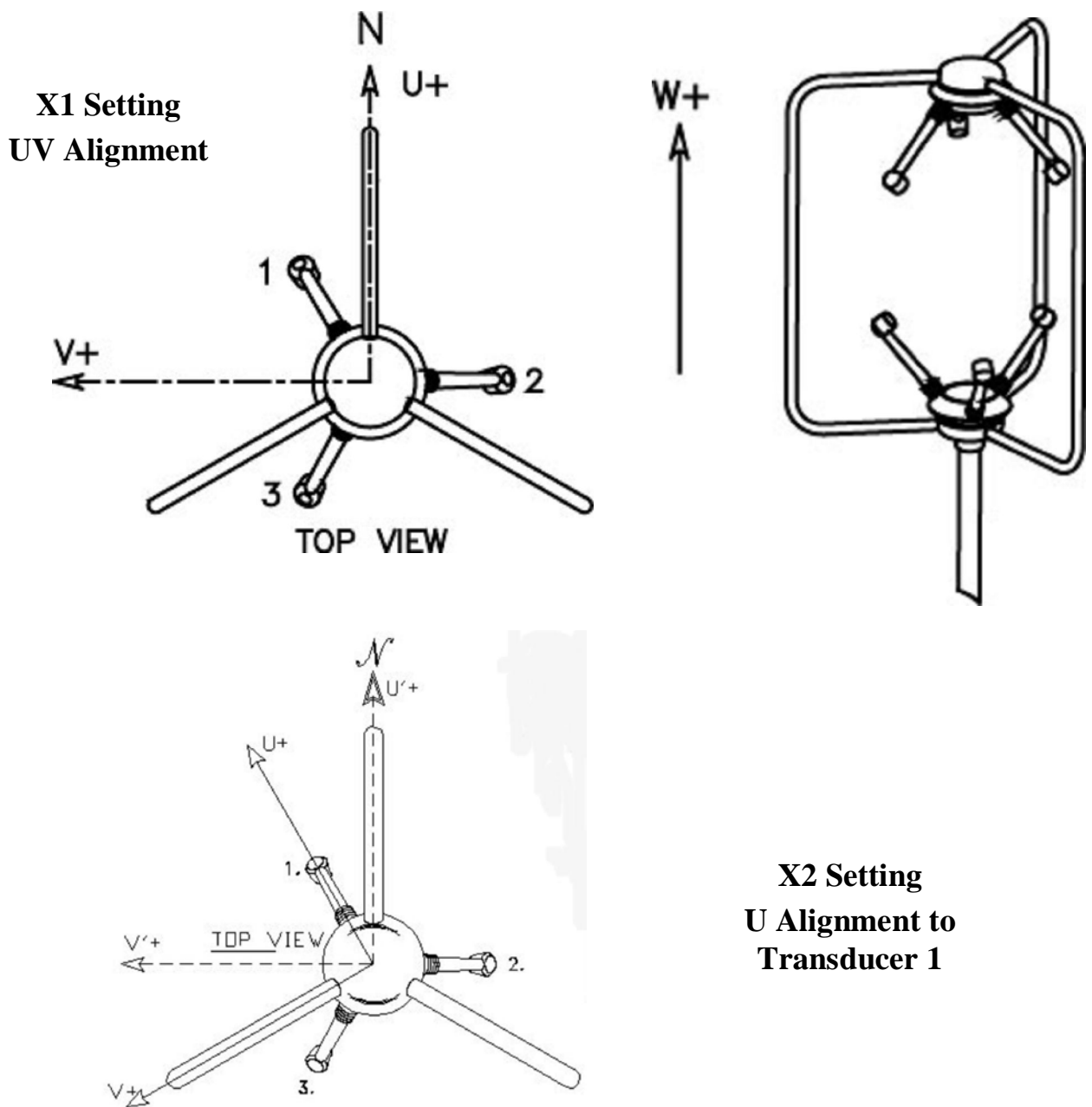

Effects of temperature, barometric pressure, rainfall and humidity

The calculated u, v and w components are independent of temperature, pressure, rainfall & humidity within the operating parameters of the WindMaster.

The calculated sonic temperature/speed of sound should be corrected by the user for humidity to provide an indication of ambient temperature. The calculated Sonic Temperature/Speed of Sound is corrected internally for crosswind.

Measurement sequence

The table shows the firing sequence of the transducers.

Measurement Sequence

The sample rate is automatically selected to either 20Hz or 32Hz, depending on the output rate configured (see section 10.2).

Measurement Period	Max 50ms (at 20Hz) or 31ms (at 32Hz)						Next cycle			
Ultrasonic Measurement Axis	1 (6ms Typical)		2		3		Maths Routine	1		2
Transducer Firing	L > U	U > L	L > U	U > L	L > U	U > L		L > U	U > L	L > U etc
Analogue Input Measurement	1, 2, 3 and 4 or PRT									
Serial Communications							Data from previous measurement.			

L > U Indicates lower to upper transducer firing.

U > L Indicates upper to lower transducer firing.

Analogue inputs and PRT are sampled synchronously at rates described in Para 8.3.

Signal processing

Instantaneous Sampling

The WindMaster can be configured to output the sampled data direct at the selected output rate without any averaging - "Instantaneous Sampling". Alternatively data can be sampled at 20Hz or 32Hz and averaged (see section 10.2 Fx y and Px). This applies for wind data and speed of sound. All samples are transmitted with a status code.

Retries Enabled

If this mode is selected, if a problem sample is detected, the unit will attempt another ultrasonic firing within the set time parameters.

Calibration Enabled /Disabled

The on-board calibration (providing compensation for spar and transducer shadowing), can be disabled, returning the unit to raw, uncorrected operation

Selection of the above parameters is via using Gill Wind software package or using a Terminal Program to set the FX or Px command.

4. SPECIFICATION

	WindMaster	WindMaster Pro
Outputs		
Output rate	1, 2, 4, 8, 10, 16, 20, (32 option) Hz	1, 2, 4, 8, 10, 16, 20, 32 Hz
Sample rate (automatically selected)	20 or 32 Hz	20 or 32 Hz
Units of measure	m/s, mph, KPH, knots, ft/min	m/s, mph, KPH, knots, ft/min
Format	UVW or Polar	UVW or Polar
Averaging	Flexible 0 - 3600 s	Flexible 0 - 3600 s
Wind Speed		
Range	0 - 45 m/s	0 - 65 m/s
Resolution	0.01 or 0.001 m/s	0.01 or 0.001 m/s
Accuracy (12 m/s) (Standard)*	< 1.5% RMS	< 1.5% RMS
Accuracy (12 m/s) (to special order)* #	< 1.0 % RMS	< 1.0 % RMS
Direction		
Range	0 – 359.9°	0 – 359.9°
Resolution	1° or 0.1°	1° or 0.1°
Accuracy (12 m/s) (Standard)*	2°	2°
Accuracy (12 m/s) (to special order)* #	0.5°	0.5°
Speed of Sound		
Range	300 -370 m/s	300 -370 m/s
Resolution	0.01 m/s	0.01 m/s
Accuracy	< ± 0.5% @ 20°C	< ± 0.5% @ 20 °C
Power requirement	9 -30 V dc, (55 mA @ 12 V dc) (excluding analogue outputs)	9 -30 V dc, (55 mA @ 12 V dc) (excluding analogue outputs)
Digital output		
Protocol (ASCII and Binary)	RS232, RS422, RS485	RS232, RS422, RS485
Baud rates	2400 - 57600	2400 - 57600
Analogue outputs (optional)		
4 channels	Resolution 12 or 14 bit	Resolution 14 bit
Selectable range	User selectable full scale wind speed	User selectable full scale wind speed
Output type	0-20 mA, 4-20 mA, 0-5V, ±5V, ±2.5V	0-20 mA, 4-20 mA, 0-5V, ±5V, ±2.5V
Analogue inputs (optional)		
Up to 4 single-ended or 2 differential	Resolution 12 or 14 bit	Resolution 14 bit, plus PRT 100ohm (option)
Input range	±5 V	±5 V
Sonic temperature		
Range	-40 °C to +70 °C	-40 °C to +70 °C
PRT		
Resolution	Not Applicable	0.01°C
Measurement Accuracy	Not Applicable	<±0.1 °C (-40 to +50°C)
Measurement Accuracy	Not Applicable	<±0.15°C (+50 to +70°C)
General		
Weight	1.0 kg	1.7 kg
Size	750 mm x 240 mm	750 mm x 240 mm
Environmental	IP65	IP65
Operating temperature	-40 °C to +70 °C	-40 °C to +70 °C
Humidity	< 5 % to 100 %	< 5 % to 100 %
Precipitation	Operation up to 300 mm / hour	Operation up to 300 mm / hour
EMC	Emissions BS EN 61000 - 6 - 3 Immunity BS EN 61000 - 6 - 2	Emissions BS EN 61000 - 6 - 3 Immunity BS EN 61000 - 6 - 2

* Accuracy specification applies for wind speed up to range maximum, and for wind incidence up to ± 30 ° from the horizontal.

Custom calibration (to be specified when ordering, or unit can be returned for calibration) - Wind tunnel calibration is in accordance with ISO 16622 and traceable to national standards.

陕西威瑞仪器仪表有限公司 生产代理销售：实验检测设备气象科学仪器设备

Tel:18966887800 Web:www.xavery.cn Email:verytrade@163.com

5. PRE-INSTALLATION

5.1. Equipment supplied

WindMaster or WindMaster Pro

Connector assembly comprising 31 way Clipper connector
Solder bucket pins
Sealing gland and washer

Installation kit Four M6 stainless steel nuts, bolts and shake-proof washers

User Manual (this document) on a CD.

5.2. Software

WIND software is available free at www.gill.co.uk, and is strongly recommended as it provides an easy, user-friendly interface.

5.3. Options

Notes These options must be specified when ordering the WindMaster or WindMaster Pro.

See Section 4 Specification for more detail

	WindMaster	WindMaster Pro
Four Analogue outputs	12 or 14 bit (specify)	14 bit
Four Analogue inputs	12 or 14 bit (specify)	14 bit
PRT input	Not available	Specify when ordering
Wind tunnel calibration, traceable to national standards	Specify when ordering *	Specify when ordering *

* Units may be returned to Gill for Wind tunnel calibration.

5.4. Accessories

Item	Part No
Travelling case - Portable protective case (WindMaster)	1210 - 30 -074
Travelling case - Portable protective case (WindMaster Pro)	1561 - 00 - 028
Spare 31 way Clipper connector	1561 - PK - 050
Spare 15m lead - one end free, other end fitted with Clipper pins	1561 - 10 - 018
Power Supply and Interface Unit (PCI)	1189 - PK - 021
Pipe mount adaptor	1561 - 30 - 025

5.5. Packaging

Whilst the WindMaster is being moved to its installation site, the unit should be kept in its packaging. All the packaging should be retained for use if the unit has to be returned at any time.

Note that if the WindMaster is to be regularly moved around, a travelling case is available as an optional extra

5.6. Installation requirements

PC requirement

The new *WIND* software will operate with any PC with Windows software from Windows 98 onwards.

The PC must be fitted with a suitable interface to match the chosen communication format - RS232, RS422, or RS485. Alternatively a Gill Power Supply and Interface (PCI) may be used to convert RS422/485 output to RS232.

Other equipment

Analogue inputs / outputs must be compatible with the options fitted to the WindMaster or WindMaster Pro.
See Sections 8 and 9

Connection

- The unit is fitted with a modified 31 way Clipper industrial plastic connector (shell size 3), and supplied with a mating plug with solder bucket pins for installation by the user.
- The cable should be securely fixed with cable clamps or equivalent, so that the cable is not under stress at the plug.
- There are restrictions on the maximum cable lengths for correct operation. *See 6.4*
- The cable should be routed up the inside of the mounting tube.
- See 6.3 for cable specification.

Power supply

- The WindMaster requires a DC supply of between 9 – 30 V DC.
- Typical current drain 55 mA @ 12 V (excluding analogue outputs)

6. INSTALLATION

6.1. Installation Guidelines

As with any sophisticated electronics, good engineering practice should be followed to ensure correct operation.

- Always check the installation to ensure the WindMaster is not affected by other equipment operating locally, which may not conform to current standards, e.g. radio/radar transmitters, boat engines, generators etc.
- Guidelines –
 - Avoid mounting in the plane of any radar scanner – a vertical separation of at least 2m should be achieved.
 - Radio transmitting antennas, the following minimum separations (all round) are suggested.
 - VHF IMM – 1m
 - MF/HF – 5m
 - Satcom – 5m (avoid likely lines of sight)
- Use cables recommended by Gill. If cables are cut and re-connected incorrectly (perhaps in a junction box) then EMC performance may be compromised if cable screen integrity is not maintained.
- Earth loops should not be created – wire the system in accordance with the installation guidelines.
- Ensure the power supply operates to the WindMaster specification at all times.

6.2. Bench system test

Note: Prior to physically mounting the WindMaster in its final location, we strongly recommend that a bench system test be carried out to confirm the system is configured correctly, is fully functional and electrically compatible with the selected host system and cabling (preferably utilising the final cable length). The required data format, units, output rate, and other options should also all be configured at this stage.

6.3. Cable type

An RS232 / RS422 compatible cable (as appropriate) should be used, with the number of twisted pairs matching the application.

Generic description – Twisted pairs with drain wire, screened with aluminised tape, with an overall PVC sheath. Wire size 7/0.2mm (24 AWG)

Gill 15m lead - A nine pair, 15metre lead, with one end free and the other end fitted with Clipper pins, is available as an accessory from Gill, see 5.4 Accessories for part number.

The table shows some suitable manufacturers' references; other manufacturers' equivalents can be used.

No. of pairs	Gill ref.	Belden ref.	Batt electronics ref.
9	026 - 02663	8774	91009

The cable allows for the connection of all: -

Power inputs

Digital data inputs and outputs

Analogue inputs

Analogue Outputs

Note: If PRT input option is selected customer must compromise on the number of enclosed inputs or outputs. If PRT is connected you must sacrifice two analogue inputs or outputs.

Other example cable types are:-

No. of pairs	Gill ref.	Belden ref.	Batt electronics ref.
2	-	9729	-
3	026 - 02660	9730	91030
4	026-03156	9728	91199

6.4. Cable length

The maximum cable length is dependent on the chosen communication format (RS232, RS422 or RS485), the baud rate, and, to a lesser extent, on the cable type and the local electrical 'noise' level.

Communication format	Baud rate	Max. cable length
RS232	9600	6.5 m (20 ft) or if using Cat 5 cable see manufacturers recommendations
RS422/485	9600	1 km (3200 ft)
Analogue outputs - voltage	N/A	6.5 m (20 ft)
Analogue outputs - current	N/A	Resistance dependent (max 300 Ω)

The table shows the typical maximum lengths at the given baud rates, using the recommended cable. If any problems of data corruption etc are experienced, then a slower baud rate should be used. Alternatively, a thicker or higher specification cable can be tried.

6.5. Connections

Important

- **Do NOT join any of the cores of the cable together.**
Any cores not used should be isolated.
- **Do NOT connect the unit's analogue output 0V or power 0V to the screen or ground / earth.**
- **The integrity of the screen of each pair should be maintained throughout the cable run.**
- **Avoid long grounding loops.**

For maximum lightning protection it is essential that the unit be properly grounded via its mounting base.

Function	Remarks	Pin No
TXA (-)	Anemometer Transmit -	1
TXB (+)	Anemometer Transmit +	2
RXB (+)	Anemometer Receive +	5
RXA (-)	Anemometer Receive -	6
Communications Mode	Polarity sets Comms mode Connect to V+ for RS232 Connect to 0v for RS422/RS485	4
Power V+	9 – 30 V	11
Power 0V	Use also for digital comms 0V	12
Analogue Output 1		8
Analogue Output 2		14
Analogue Output 3		9
Analogue Output 4		15
PRT Excitation +		19
PRT Excitation -		20
PRT Sense +		25
PRT Sense -		26
Analogue Input 1		27
Analogue Input 2		28
Analogue Input 3		29
Analogue Input 4		24
Analogue Grounds	Use the most convenient pin	10, 16, 17
Screens	Use the most convenient pin	3, 7, 21, 30, 31
Not connected		13, 18, 22, 23

Cable assembly

Open the pack of parts (1561-PK-050) provided with the WindMaster.

Strip the cable and solder the contact pins to the cores (please note that the connector supplies the correct strain relief for cables with an outside diameter of 6-12mm).

Put the parts on the cable in the order as shown below.



Whilst squeezing the red retainers in the direction of ARROW A, pull in the direction of ARROW B.

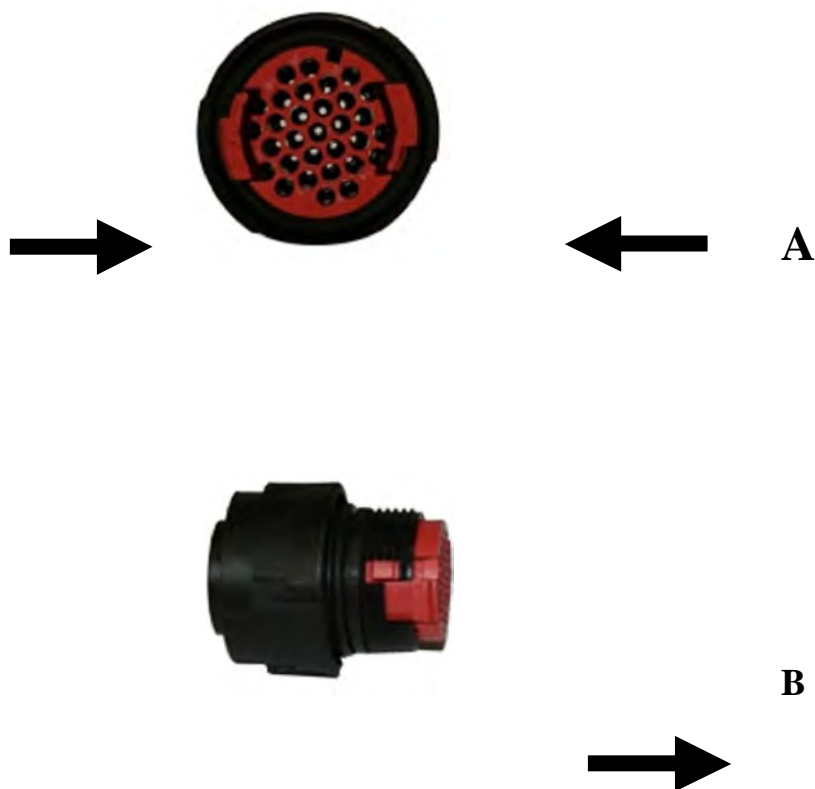

Your connector should now resemble the connector in the picture above.

Insert each contact pin until you feel a slight click. If you have inserted the contact into the incorrect hole it can be removed at this point by simply pulling it out. Please note there will be some resistance.



Continue to insert all of the contacts you require in accordance with the diagram below.

Connector Pin & Conductor positions

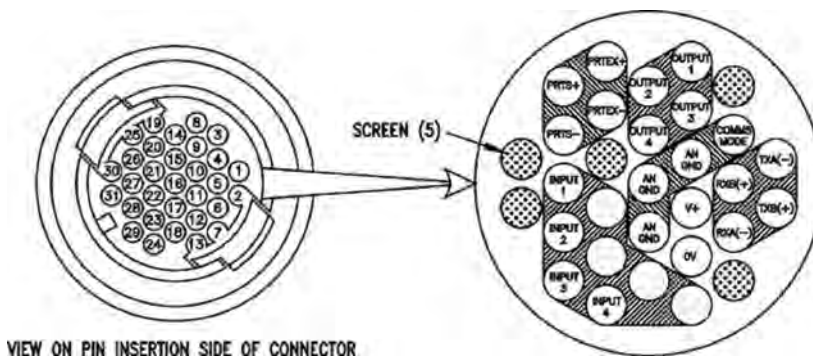

The drawing above shows the pin positions of the wire conductors, together with position of conductor screens. This information must be used in conjunction with the information shown in 6.5 connections. If the PRT option is selected you may have to sacrifice two analogue inputs or outputs.

Once all of the contacts are inserted push the red retainer into place.

NB. The retainer can only be pushed back into place if the contacts are fully engaged.

Fit the connector to the WindMaster so that you can now finish assembling the connector.

Screw the back-shell onto the connector until it is fully in place. Please note that the final rotations can be slightly stiff



Screw the cable clamp into the back shell



Now screw the cable-clamping nut into place



The connector can now be removed from the WindMaster.

Grounding (Earthing)

To ensure correct operation, and for maximum protection against lightning, the anemometer **MUST** be correctly grounded (earthed) via its mountings. Inadequate grounding will degrade anemometer performance, particularly in the presence of radio frequency interference.

The unit **MUST** be connected to an appropriate grounding point with a minimum of 6mm² copper wire, via the M6 base screws. The primary earth for the anemometer must be provided via the base screws and not via the cable screens.

6.6. Connection to a PC using RS 232

Notes

1. Using RS232, the cable length for reliable operation is limited to 6.5m (20ft) @ 9600 Baud. *See 6.4*
2. For longer cable runs, we recommend using the WindMaster configured with RS422 output, and a RS422/232 converter at the PC. *See 6.7*
3. Ensure WindMaster is configured for AUTO or RS232. *See Section 10 Configuring*

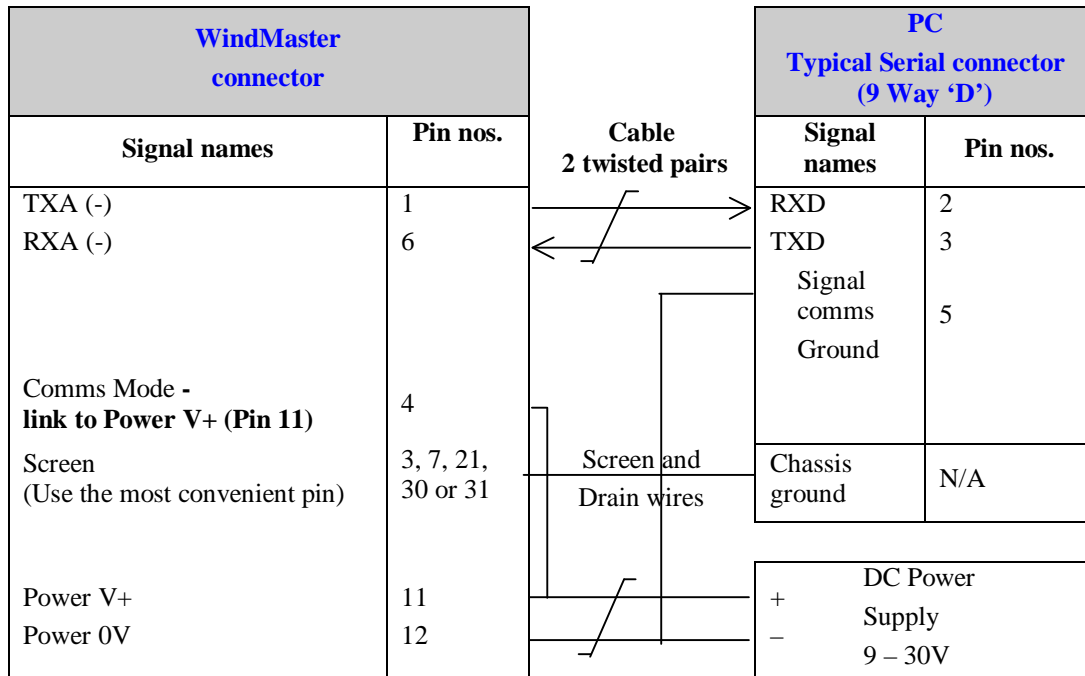

6.7. Connection to a PC using RS 422

Notes

1. The PC must be fitted with an internal or external RS422 / RS232 converter.
2. Configure WindMaster for RS 422 by linking Comms Mode line (Pin 4) to 0V (Pin 12)

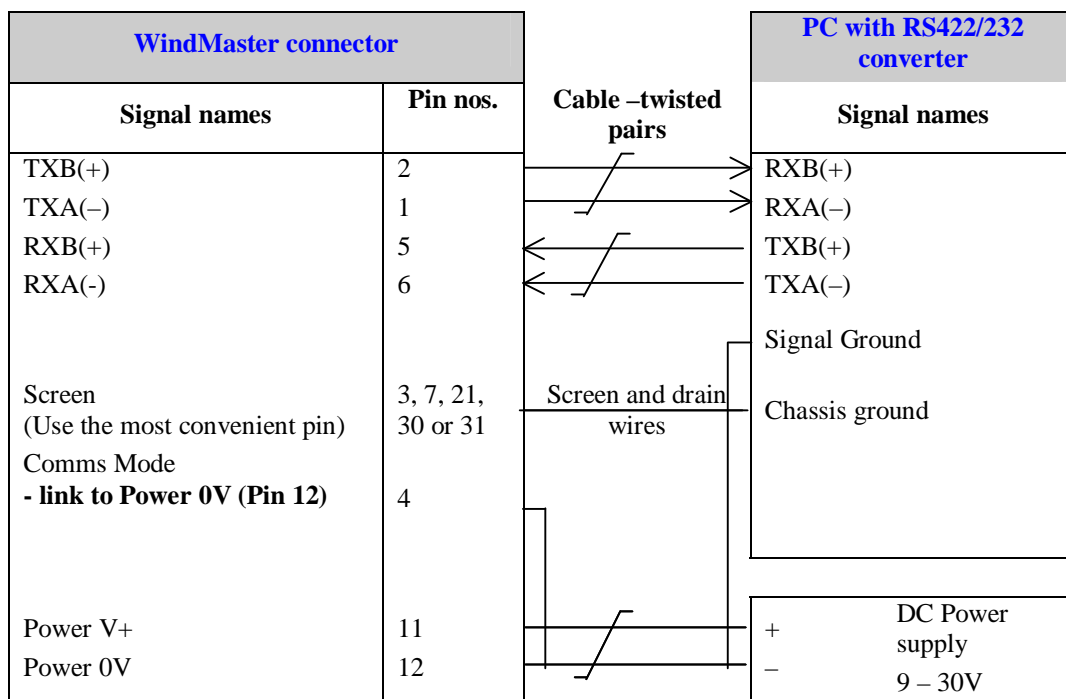

6.8. Connection to a PC via a Power and Communications Interface

Dependent upon system requirements the WindMaster unit can be operated with the Power and Communications and Interface unit (PCI), which can be ordered as an optional extra. Connect WindMaster via RS422 port; then connect computer to RS232 port on PCI.

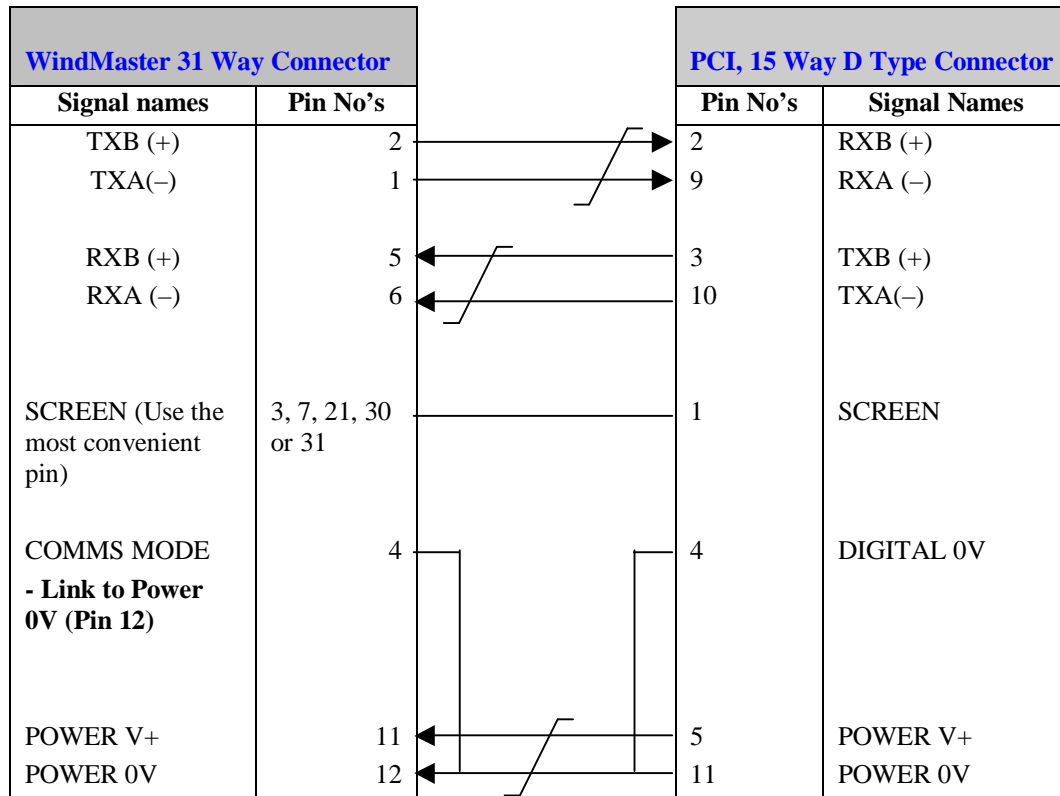

Environmental

The Desktop PCI is intended for use in a protected environment and provides interfacing to a single anemometer. RS232, and RS422 ports are provided. The PCI is not intended for outdoor use.

PCI Electrical Power Requirements

- 1) 100Vac - 120Vac, 10VA for the 115V switch position
- 2) 200Vac - 250Vac, 10VA for the 230V switch position
- 3) 9 - 30Vdc, 55mA excluding analogue outputs (anemometer)
8 - 15Vdc, 50mA max (interface)

3 fuses protect the unit:

1. Externally accessible 1 A (T) for 115/230v operation
2. Internally accessible 500 mA (T) AUX
500 mA (T) ANEM

Connector Pin and Cable Assignments for PCIA

Anemometer Connector 15 - Way	
Pin	Designation
1	Screen
2	RS422_RXB (+)
3	RS422_TXB (+)
4	Digital 0V, Signal ground
5	Supply V+
6	Analogue output V1
7	Not used
8	Analogue output V2
9	RS422_RXA (-)
10	RS422_TXA (-)
11	Supply V-
12	Analogue output V4
13	Analogue 0V
14	Not used
15	Analogue output V3

DC Supply 4 - Way	
Pin	Designation
1	Interface V+
2	Interface V-
3	Anemometer V-
4	Anemometer V+

RS232 Output - 9 way	
Pin	Designation
1	DCD
2	RX data
3	TX data
4	DTR
5	Signal Ground
6	DSR
7	RTS
8	CTS
9	RI

RS422/Network Input/Output 9 Way	
Pin	Designation
1	Not connected
2	Not connected
3	Not connected
4	RS422_RXA (-)
5	Signal ground
6	RS422_TXA (-)
7	RS422_TXB (+)
8	RS422_RXB (+)
9	Earth

PCIA Box WindMaster Analogue Output Connections.

	WindMaster 31 -Way Clipper Connector	PCIA Box 15 – Way D Type Connector	PCIA Auxiliary or Sync Out 9 Way D Type Connector
Function	Pin	Pin	Pin
Analogue Output 1	8	6	6
Analogue Output 2	14	8	7
Analogue Output 3	9	15	8
Analogue Output 4	15	12	9
Analogue Ground	10, 16 or 17	13	2, 3, 4 and 5 (Grounds for Analogues 1 to 4 respectively)

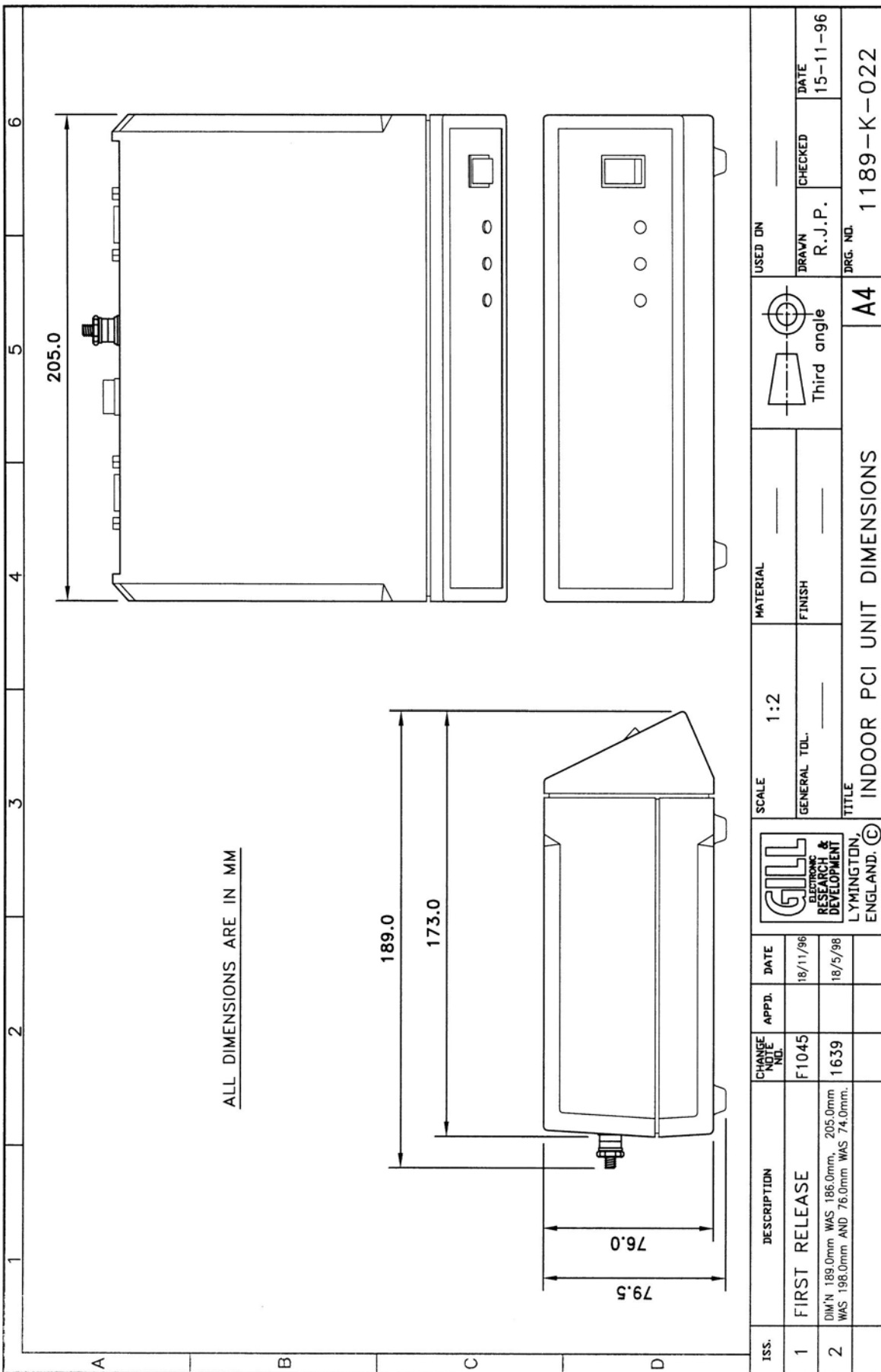

6.9. Using RS485

Notes

1. Set up the WindMaster operating configuration before wiring for RS485 mode.
2. WindMasters **must** be configured for RS485 by linking Comms Mode line (Pin 4) to 0V (Pin 12).
3. WindMasters **must** be in Polled mode.
4. The Master unit can be any suitable control device fitted with a RS485 interface card, such as a PC or Data logger.
5. Analogue Outputs are also simultaneously available from the Option 3 unit.

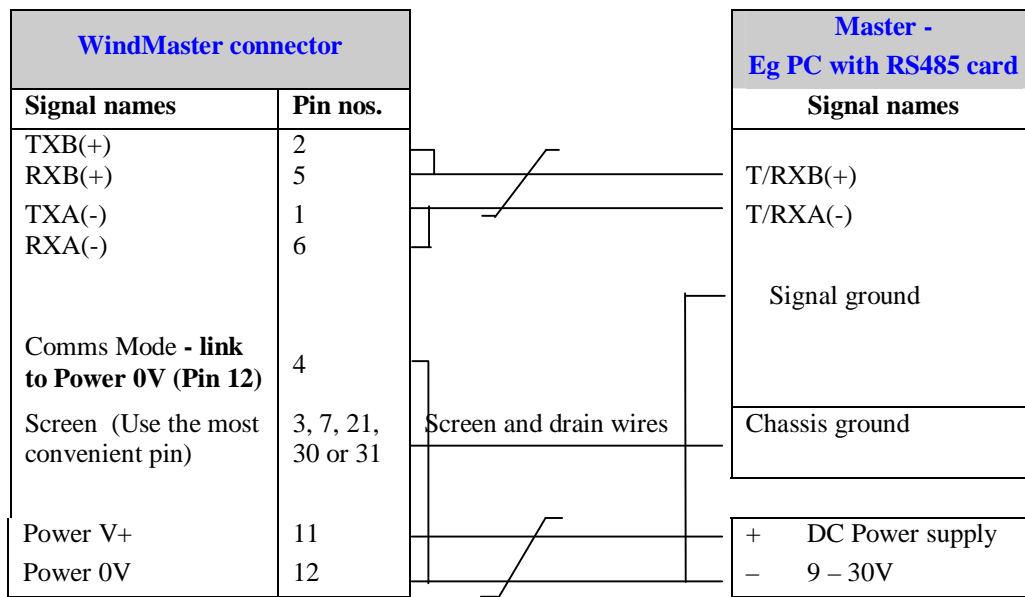

6.10. Mechanical installation

Before installing, it is strongly recommended that a bench test is carried out.

Location

Select a position so that the unit is clear of any structure, which may obstruct the airflow or induce turbulence.

Do NOT mount the WindMaster in close proximity of high-powered radar or radio transmitters. A site survey may be required if there is any doubt about the strength of external electrical noise.

Orientation

Normally the WindMaster is mounted vertically, ensuring a horizontal Measuring Plane.

However, the unit may be mounted with the Measurement Plane set to any required orientation, **provided** the sealing gasket is fitted to the flange and provision is made to seal the M4 base mounting nuts (i.e. with a rubber boot) to prevent water ingress.

Alignment and Dimensions

The reference north spar as indicated by a notch (that is in the direction line with north), which is also indicated on the base of the unit by another notch.

Figure 3 North Spar Alignment and Dimensions

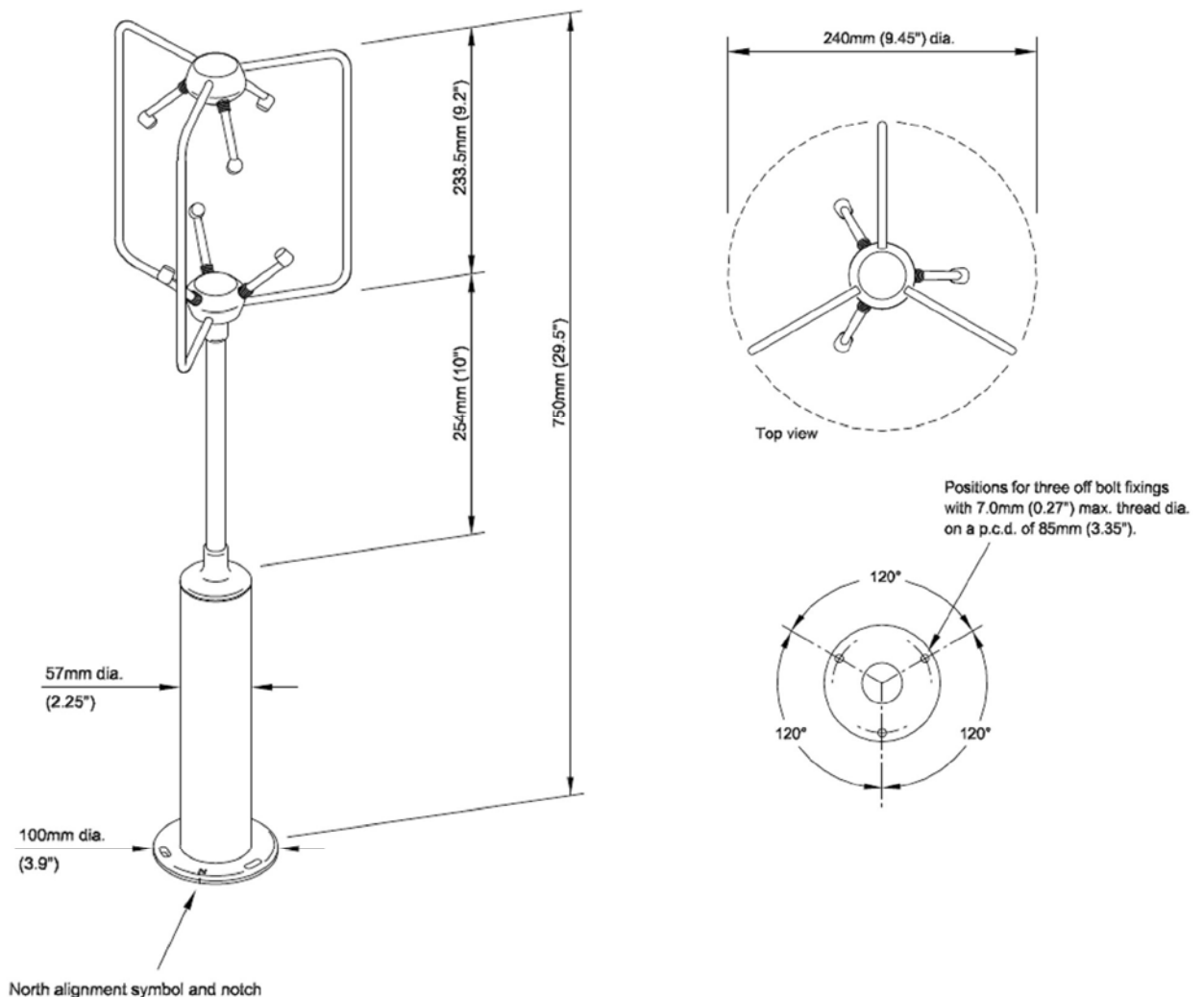

Corrosion

Careful note should be taken of the possibility of galvanic corrosion by incorrect mounting. It is vital that only stainless steel fixings are used and that the instrument is insulated from the mounting surface with the rubber gasket. This will ensure that the anemometer will provide long service under extreme conditions such as marine.

Grounding (Earthing)

For protection against lightning the WindMaster **MUST** be earthed via its mountings.

陕西威瑞仪器仪表有限公司 生产代理销售：实验检测设备气象科学仪器设备

Tel:18966887800 Web:www.xavery.cn Email:verytrade@163.com

Cable strain relief

Fit strain relief when installing such that the weight of the cable is supported and does not put a strain on the connector.

Flange mounting

Mount the unit to a suitable surface, using the flange gasket and the M6 nuts, bolts and washers provided, ensuring that the clearance for the connector is maintained as shown on Figure 3.

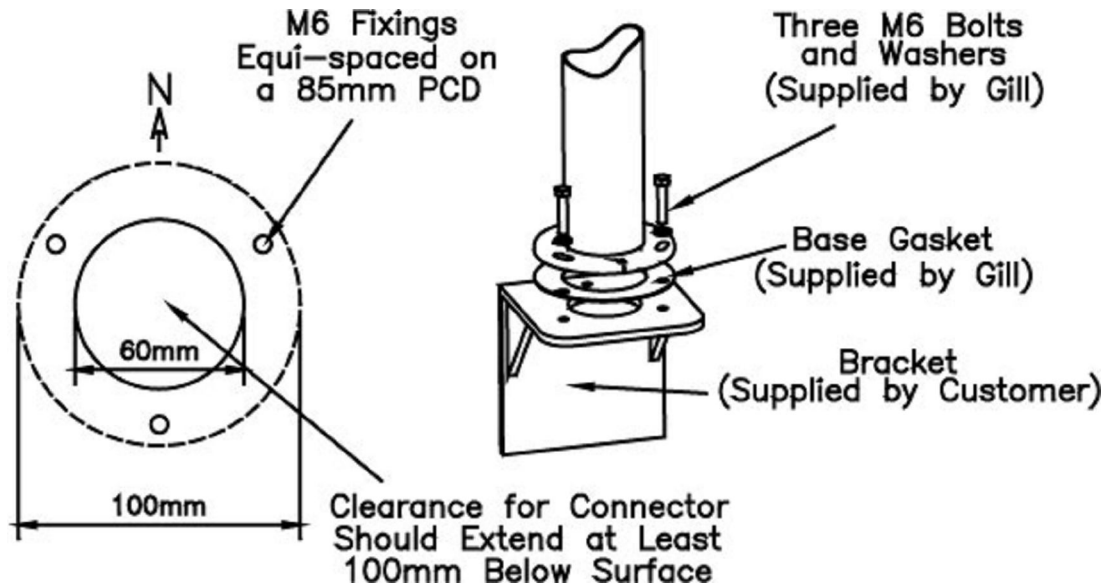

Figure 4 Flange Mounting

Pipe mount adaptor

The pipe mount adaptor enables the WindMaster to be fitted directly to a standard 1.5 inch BSP pipe (Pipe size OD 1.9", ID 1.5", wall thickness 0.2). The pipe mount adaptor must be ordered from Gill.

The WindMaster connector must be connected to the WindMaster before the pipe mount adaptor is attached to the WindMaster. Pass the cable (fitted with the 31 way Clipper plug) through the tube. Connect the plug by twisting it whilst pushing it gently into the socket on the WindMaster. When it locates, twist the outer sleeve clockwise to connect and lock the plug.

Fix the pipe mount adaptor to the pipe using the 2 stainless steel screws provided.

Note: the customer **MUST** fit appropriate strain relief to the cable - this is particularly important with pipe mounting. Mount the WindMaster unit to the pipe mount adaptor using the flange gasket and the M6 nuts, bolts and washers provided.

Figure 5 Pipe Mount Adaptor

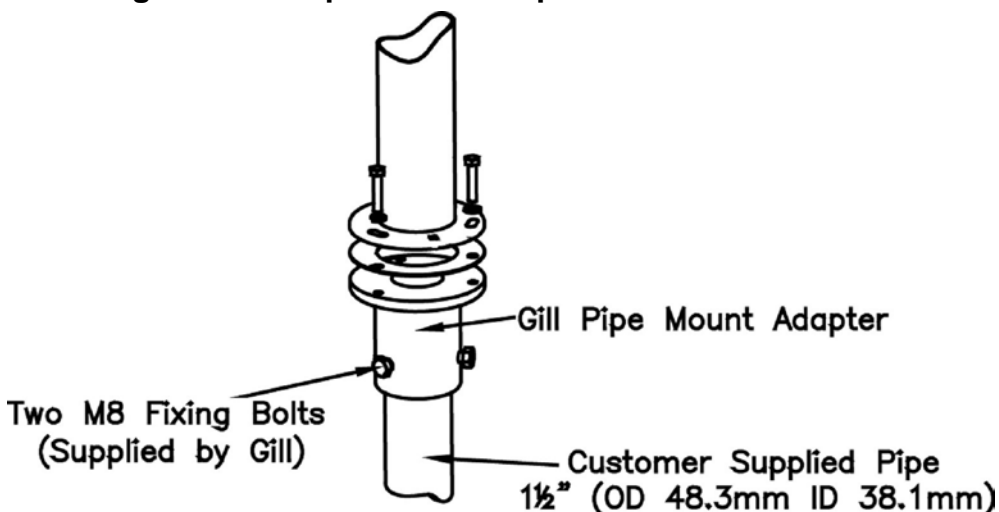

7. MESSAGE FORMATS

On applying power to the WindMaster, it will automatically operate in the Measurement Mode and provide wind measurements in one of the following formats:

- Mode 1 – ASCII, UVW, Continuous
- Mode 2 – ASCII, Polar, Continuous (**default format**)
- Mode 3 – ASCII, UVW, Polled
- Mode 4 – ASCII, Polar, Polled
- Mode 7 – Binary, Polar, Short
- Mode 8 – Binary, UVW, Short
- Mode 9 – Binary, Polar, Long
- Mode 10 – Binary UVW, Long

Note: In this Section, the default settings are shown in **Bold**.

The user need not necessarily use a terminal emulator to store and analyse data being sent by the Anemometer. This section describes the modes and format of the data output to enable specific interfacing software to be generated by the user.

Information on how to change the formats and all the settings follows in Section 10 CONFIGURING.

7.1. Mode 1– ASCII, UVW, Continuous

(a) **Mode 1, Normal Resolution (J1).**

ASCII, UVW, Continuous, Speed of Sound On, Sonic Temp On, [Analogue inputs On], PRT On

In this mode, the wind speed outputs are given as signed (i.e. positive or negative) speeds along the U axis, V axis and the W (vertical) axis.

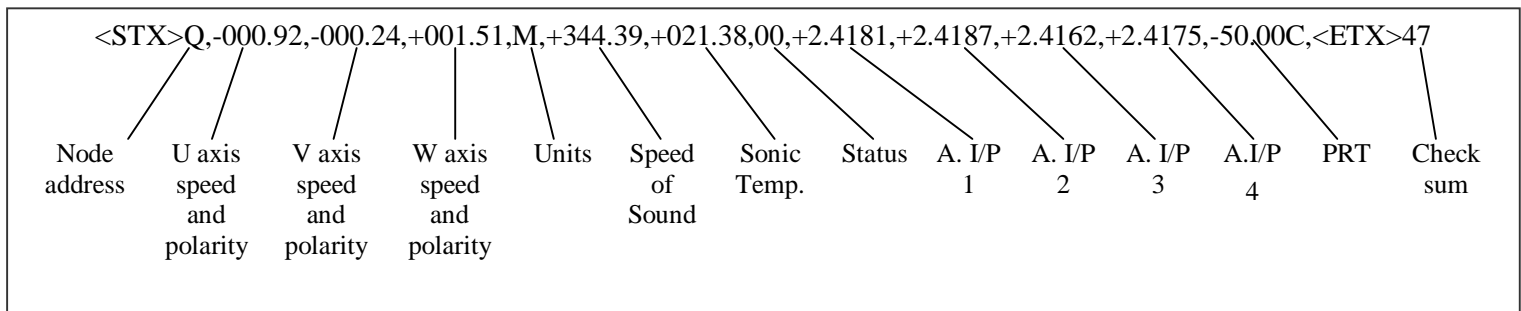

Format for software configuring is: -

```
<STX><ID>,+UUU.UU,+VVV.VV,+WWW.WW,U,+CCC.CC,+TTT.TT,SS,[+1.1111,+2.2222,+3.3333,+4.4444],+PP.PPC,<ETX>CC<CR><LF>
```

Where:

- <STX> - Start of string character (ASCII value 2)
- <ID> - Anemometer Identification (A-Z)
- ±UUU.UU - 'U' axis velocity 0.01ms⁻¹ units
- ±VVV.VV - 'V' axis velocity 0.01ms⁻¹ units
- ±WWW.WW - 'W' axis velocity 0.01ms⁻¹ units
- U - Units (M=m/s, N=knots, P=mph, K=kph)
- ±CCC.CC - Speed of Sound in 0.01ms⁻¹ units
- ±TTT.TT - Sonic Temperature in Degrees C.
- SS - Status data (Codes 00 to 0B)
- ±1.1111 - Analogue input 1 in volts
- ±2.2222 - Analogue input 2 in volts
- ±3.3333 - Analogue input 3 in volts
- ±4.4444 - Analogue input 4 in volts
- ±PP.PPC - PRT temperature in degrees C, eg +23.13deg C output as +23.13C in the string.
- <ETX> - End of string character (ASCII value 3)
- CC - Checksum of all Characters between <STX> and <ETX> (HEX byte)
- <CR><LF> - Carriage Return and Line Feed

<STX>

Start of string character (ASCII value 2)

WindMaster Identification node address

The default setting is 'Q'.

Horizontal wind speed

Shows the wind speed in the U / V Plane. *See Fig 2*

Vertical wind speed

Shows the magnitude of wind speed in the W axis. *See Fig 2*

Units

The Units identifier shows the units in which the wind speeds are measured.

Units	Identifier
Metres per second (default)	M
Knots	N
Miles per hour	P
Kilometres per hour	K
Feet per minute	F

Speed of Sound (SOS)

If enabled, this is displayed in metres per second.

Sonic temperature

If enabled, this is displayed in degrees C.

Status

This indicates either correct operation - Code 00 - or status code. *See 11.4 for explanation of codes.*

Analogue Inputs (Unit order option)

If enabled, the four Analogue inputs are an order option (see Para 8.1)

PRT (Unit order option)

If enabled, the Platinum Resistance Thermometer input is an order option (see Para 8.2).

Checksum

This enables the host system to check that the data has been correctly received. This is the EXCLUSIVE – OR of the bytes between (and not including) the <STX> and <ETX> characters reported as ASCII Hex.

<ETX>

End of string character (ASCII value 3)

Output rate (not displayed)

The WindMaster delivers wind information at rates from 1 (default setting) to 32 outputs / second.

[The sample rate (20 or 32 Hz) is chosen automatically to be an appropriate multiple of the output rate.]

Data can be instantaneous or averaged (see section 10)

(b) Mode 1 (High Resolution (J2))**ASCII, UVW, Continuous, Speed of Sound On, Sonic Temp On, [Analogue inputs On], PRT On**

<STX><ID>,±UUU.UUU,±VVV.VVV,±WWW.WWW,U,±CCC.CC,±TTT.TT,
SS,[±1.1111,±2.2222,±3.3333,±4.4444],±PP.PPC,<ETX>CC<CR><LF>

Where:

<STX>	-	Start of string character (ASCII value 2)
<ID>	-	Anemometer Identification (A-Z)
±UUU.UUU	-	'U' axis velocity 0.001ms^{-1} units
±VVV.VVV	-	'V' axis velocity 0.001ms^{-1} units
±WWW.WWW	-	'W' axis velocity 0.001ms^{-1} units
U	-	Units (M=m/s)
±CCC.CC	-	Speed of Sound in 0.01ms^{-1} units
±TTT.TT	-	Sonic Temperature in Degrees C.
SS	-	Status data (Codes 00 to 0B)
±1.1111	-	Analogue input 1 in volts
±2.2222	-	Analogue input 2 in volts
±3.3333	-	Analogue input 3 in volts
±4.4444	-	Analogue input 4 in volts
±PP.PPC	-	PRT temperature in degrees C, eg +23.13deg C output as +23.13C in the string.
<ETX>	-	End of string character (ASCII value 3)
CC	-	Checksum of all Characters between <STX> and <ETX> (HEX byte)
<CR><LF>	-	Carriage Return and Line Feed

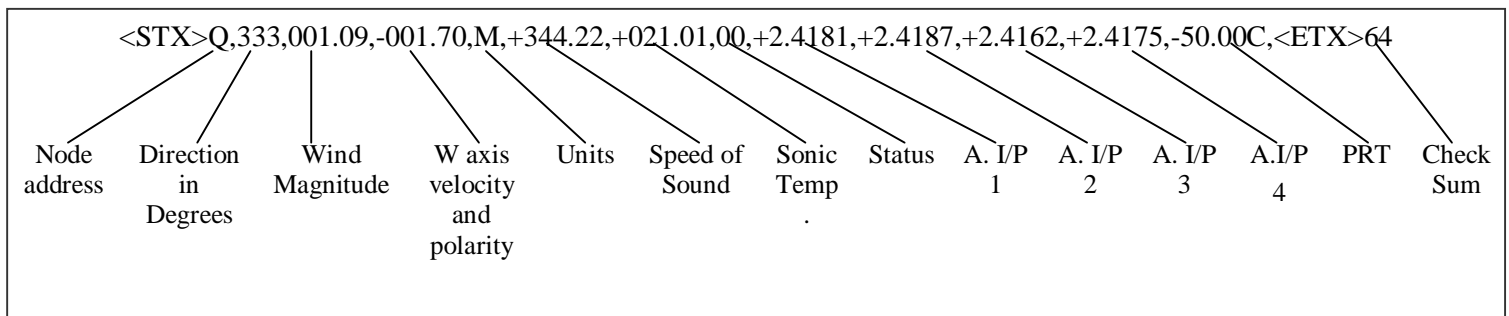
7.2. Mode 2 – ASCII, Polar, Continuous (Default)**(a) Mode 2 (Normal Resolution Shown J1)****ASCII, Polar+W, Continuous, Speed of Sound On, Sonic Temp On, [Analogue inputs On], PRT On**

Format for software configuring is:-

<STX><ID>,DDD,MMM.MM,±WWW.WW,U,±CCC.CC,±TTT.TT,SS,[±1.1111,±2.2222,±3.3333±4.4444],
±PP.PPC,<ETX>CC<CR><LF>

Where:

<STX>	-	Start of string character (ASCII value 2)
<ID>	-	Anemometer Identification (A-Z)
DDD	-	Direction in degrees
MMM.MM	-	Wind Magnitude
±WWW.WW	-	'W' axis velocity 0.01ms^{-1} units
U	-	Units (M=m/s, N=knots, P=mph, K=kph)
±CCC.CC	-	Speed of Sound in 0.01ms^{-1} units
±TTT.TT	-	Sonic Temperature in Degrees C.
SS	-	Status data (Codes 00 to 0B)
±1.1111	-	Analogue input 1 in volts
±2.2222	-	Analogue input 2 in volts
±3.3333	-	Analogue input 3 in volts
±4.4444	-	Analogue input 4 in volts
±PP.PPC	-	PRT temperature in degrees C, eg +23.13deg C output as +23.13C in the string.
<ETX>	-	End of string character (ASCII value 3)
CC	-	Checksum of all Characters between <STX> and <ETX> (HEX byte)
<CR><LF>	-	Carriage Return and Line Feed

Parameters are as described in Para 7.1 except that :-

陕西威瑞仪器仪表有限公司 生产代理²销售: 实验检测设备气象科学仪器设备

Tel:18966887800 Web:www.xavery.cn Email:verytrade@163.com

Horizontal wind direction

Indicated in degrees, from 0 to 359°, with respect to the WindMaster North marker.

In fixed field mode and when the wind speed is below 0.05 metres/sec, the direction will not be calculated, but the last calculated direction above 0.05 m/s will be output (the threshold of 0.05 m/s is the default setting; it is user-configurable).

(b) Mode 2 (High Resolution Shown J2)

ASCII, Polar+W, Continuous, Speed of Sound On, Sonic Temp On, [Analogue inputs On], PRT On

```
<STX><ID>,DDD.D,MMM.MMM,±WWW.WWW,U,±CCC.CC,±TTT.TT,SS,[±1.1111,±2.2222,±3.3333
±4.4444],±PP.PPC,<ETX>CC<CR><LF>
```

Where:

<STX>	-	Start of string character (ASCII value 2)
<ID>	-	Anemometer Identification (A-Z)
DDD.D	-	Direction in degrees
MMM.MMM	-	Wind Magnitude
±WWW.WWW	-	'W' axis velocity 0.001ms^{-1} units
U	-	Units (M=m/s)
±CCC.CC	-	Speed of Sound in 0.01ms^{-1} units
±TTT.TT	-	Sonic Temperature in Degrees C.
SS	-	Status data (Codes 00 to 0B)
±1.1111	-	Analogue input 1 in volts
±2.2222	-	Analogue input 2 in volts
±3.3333	-	Analogue input 3 in volts
±4.4444	-	Analogue input 4 in volts
±PP.PPC	-	PRT temperature in degrees C, eg +23.13deg C output as +23.13C in the string.
<ETX>	-	End of string character (ASCII value 3)
CC	-	Checksum of all Characters between <STX> and <ETX> (HEX byte)
<CR><LF>	-	Carriage Return and Line Feed

7.3. Mode 3 –ASCII, UVW, Polled.

Mode 3 (Normal Resolution Shown)

ASCII, UVW, Polled, Speed of Sound On, Sonic Temp On, [Analogue inputs On], PRT On

```
<STX><ID>,±UUU.UU,±VVV.VV,±WWW.WW,U,±CCC.CC,
±TTT.TT,SS,[±1.1111,±2.2222,±3.3333±4.4444],±PP.PPC,<ETX>CC<CR><LF>
```

Where:

<STX>	-	Start of string character (ASCII value 2)
<ID>	-	Anemometer Identification (A-Z)
±UUU.UU	-	'U' axis velocity 0.01ms^{-1} units
±VVV.VV	-	'V' axis velocity 0.01ms^{-1} units
±WWW.WW	-	'W' axis velocity 0.01ms^{-1} units
U	-	Units (M=m/s, N=knots, P=mph, K=kph)
±CCC.CC	-	Speed of Sound in 0.01ms^{-1} units
±TTT.TT	-	Sonic Temperature in Degrees C.
SS	-	Status data (Codes 00 to 0B)
±1.1111	-	Analogue input 1 in volts
±2.2222	-	Analogue input 2 in volts
±3.3333	-	Analogue input 3 in volts
±4.4444	-	Analogue input 4 in volts
±PP.PPC	-	PRT temperature in degrees C, eg +23.13deg C output as +23.13C in the string.
<ETX>	-	End of string character (ASCII value 3)
CC	-	Checksum of all Characters between <STX> and <ETX> (HEX byte)
<CR><LF>	-	Carriage Return and Line Feed

Polled Mode Notes

When in the Polled mode, an output is only generated when the host system sends a Poll signal to the WindMaster consisting of the WindMaster Unit Identifier – that is, the relevant letter A – Z.

The default setting is ‘Q’.

The commands available in Polled Mode are :

Description	Command	WindMaster Response
WindMaster Unit Identifier	A Z	Wind speed output generated
Enable Polled mode	?	(none)
Disable Polled mode	!	(none)
Request WindMaster Unit Identifier	&	A Z (as configured)
Enter Configuration mode	*<N>	CONFIGURATION MODE

* Where <N> is the Unit Identifier.

It is suggested that in polled mode the following sequence is used for every poll for information.

? Ensures that the Sensor is enabled to cover the event that a power down has occurred.

A-Z Appropriate unit designator sent to retrieve a line of data.

! Sent to disable poll mode and reduce possibility of erroneous poll generation.

If the unit is powered down after use or upon switch on then allow 3 seconds from switch on before sending poll commands.

Maximum poll rate is 10Hz.

7.4. Mode 4 –ASCII, Polar, Polled.

Mode 4 (Normal Resolution Shown)

ASCII, Polar+W, Polled, Speed of Sound On ,Sonic Temp On, [Analogue inputs On], PRT On

<STX><ID>,DDD,MMM.MM,±WWW.WW,U,±CCC.CC,±TTT.TT,SS,[±1.1111,±2.2222,
±3.3333±4.4444],±PP.PPC,<ETX>CC<CR><LF>

Where:

<STX>	-	Start of string character (ASCII value 2)
<ID>	-	Anemometer Identification (A-Z)
DDD	-	Direction in degrees
MMM.MM	-	Wind Magnitude
±WWW.WW	-	‘W’ axis velocity 0.01ms^{-1} units
U	-	Units (M=m/s, N=knots, P=mph, K=kph)
±CCC.CC	-	Speed of Sound in 0.01ms^{-1} units
±TTT.TT	-	Sonic Temperature in Degrees C.
SS	-	Status data (Codes 00 to 0B)
±1.1111	-	Analogue input 1 in volts
±2.2222	-	Analogue input 2 in volts
±3.3333	-	Analogue input 3 in volts
±4.4444	-	Analogue input 4 in volts
±PP.PPC	-	PRT temperature in degrees C, eg +23.13deg C output as +23.13C in the string.
<ETX>	-	End of string character (ASCII value 3)
CC	-	Checksum of all Characters between <STX> and <ETX> (HEX byte)
<CR><LF>	-	Carriage Return and Line Feed

See also Polled Notes above.

7.5. Mode 7 –Binary, Polar, Short

<B1><B1>STATUS,DIR,MAG,W,SOS,CHECKSUM

<B1> -

<B1> -

STATUS -	Status data (Codes 00 to 10)
DIR	Wind Direction
MAG	Wind Speed
W	W axis velocity
SOS	Speed of Sound in 0.01ms
CHECKSUM	

Notes:-

Data is 2 byte signed two's complement (except unsigned for SOS; 1 byte for checksum).

Velocities are normal resolution (0.01m/s).

Outputs that are disabled are padded with zero to give fixed size records.

Gill WinConvert now includes decode for WM binary data in addition to R3.

7.6. Mode 8 –Binary, UVW, Short

<B2><B2>STATUS,U,V,W,SOS,CHECKSUM

<B2> -

<B2> -

STATUS -	Status data (Codes 00 to 0B)
U	U axis velocity
V	V axis velocity
W	W axis velocity
SOS	Speed of Sound in 0.01ms^{-1}
CHECKSUM	

7.7. Mode 9 –Binary, Polar, Long

<B3><B3>STATUS,DIR,MAG,W,SOS,A1,A2,A3,A4,PRT,CHECKSUM

<B3> -

<B3> -

STATUS -	Status data (Codes 00 to 0B)
DIR	Wind Direction
MAG	Wind Speed
W	W axis velocity
SOS	Speed of Sound in 0.01ms^{-1}
A1	Analogue input 1
A2	Analogue input 2
A3	Analogue input 3
A4	Analogue input 4
PRT	Platinum Resistance Thermometer input
CHECKSUM	

7.8. Mode 10 –Binary, UVW, Long

One record consists of 23 Bytes:-

0xB4 0xB4 StaL StaH Wc1L Wc1H Wc2L Wc2H Wc3L Wc3H SoSL SoSH A1L A1H A2L A2H A3L A3H A4L A4L
TPrtL TPrtH,Checksum

Variable	Description	Byte
0xB4 0xB4	Start message identifier (HEX B4 = decimal 180)	1+2
Sta	Status data (Information only on low byte (Codes 00 to 0B), high byte always zero).	3+4
Wc1	U axis wind velocity (16 bit signed integer).	5+6
Wc2	V axis wind velocity (16 bit signed integer)	7+8
Wc3	W axis wind velocity (16 bit signed integer)	9+10
SoS	Speed of Sound in 0.01ms (16 bit signed integer)	11+12
A1	Analogue input 1 (16 bit signed integer).	13+14
A2	Analogue input 2 (16 bit signed integer).	15+16
A3	Analogue input 3 (16 bit signed integer).	17+18
A4	Analogue input 4 (16 bit signed integer).	19+20
TPrt	Temperature from PRT (16 bit signed integer).	21+22
Checksum	Checksum (exclusive OR of bytes between start of message identifier and checksum byte).	23

SoS is always reported as Speed of Sound independent of A command setting.

TPrt is always reported independent from the V command setting.

A1 to A4 are always reported independent from the I command setting.

8. ANALOGUE INPUTS

Options of four analogue inputs and outputs must be specified when ordering.

8.1. Analogue Inputs

The input range is fixed at $\pm 5V$

For pin connections *see 6.5 Connections*. (Must be specified when ordering)

The WindMaster can be configured for 4 single analogue inputs (Pins 27, 28, 29 and 24) or 2 differential analogue inputs. Input 1 (Pins 27 and 28) and Input 2 (Pins 29 and 24).

Notes: The Analogue inputs must be enabled if they are to be used, (See Section 10, Configuring). Averaging does not apply to Analogue inputs.

Input range	- 5 V to + 5 V
Common mode input range	$\pm 5 V$
Input impedance	310 K ohm in series with 2.5 V
Resolution	12, 14 bit (as installed)

8.2. PRT input

Available on the WindMaster Pro only. (Must be specified when ordering).

The PRT input is designed to work with any 4 wire PRT that meets IEC60751.

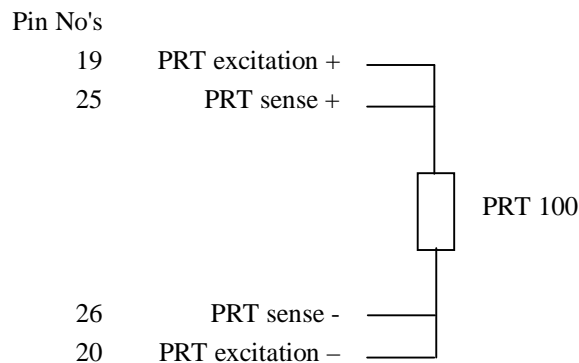

8.3. Input Rates

In single ended mode timing responses are:-

Channel	20Hz Base Rate	32Hz Base Rate
1	20Hz	32Hz
2	20Hz	16Hz
3	5Hz	4Hz
4	5Hz	4Hz
PRT	5Hz	4Hz

9. ANALOGUE OUTPUTS

Options of four analogue inputs and outputs must be specified when ordering.

Information on how to change the formats and all the settings follows in Section 10, CONFIGURING.

9.1. Output allocations

Each of the outputs can be configured to one of the following:-

U, V, W, Polar Angle (Horizontal Direction), Speed of Sound, Sonic Temperature, Status, Polar magnitude (Horizontal Wind Speed).

9.2. Output types

They are user-configurable as:- Voltage 0V to 5V, or -2.5V to +2.5V, or -5V to +5V,
Current 4 -20 mA, or 0 - 20mA.

9.3. Voltage outputs

The output impedance is less than 1 ohm. To prevent inaccuracies, the outputs should be connected to an input with an impedance greater than 10K Ω .

9.4. Current outputs

Important

When using the current outputs, the load resistance between the Output and Ground must be ≤ 300 ohms, including cable resistance.

This is to ensure that the voltage levels on the Analogue outputs do not exceed 5V.

9.5. Scaling

This is user-configurable to 5, 10, 20, 30, 40, 50, 60, or 120 m/s full scale for wind speed.

Using 50m/s and UVW setting as an example, this defines the outputs range as follows

Polar setting will range between 0 – 50m/s.

Output	Voltage 0 to 5V	Voltage $\pm 2.5V$	Voltage $\pm 5V$	Current 4 - 20 mA	Current 0 - 20 mA
U, V, W					
-50 m/s	0	-2.5	-5	4	0
0 m/s	+2.5	0	0	12	10
+50 m/s	+5	+2.5	+5	20	20

9.6. Polar wind direction wraparound

The wind direction in Polar mode can be configured for either 360° or 540° Wraparound. If the 360° mode is used with a chart recorder, large swings of the recorder pen will be experienced each time the wind direction passes between 0 and 359°. Using the 540° mode, when the wind first changes from 0° to 359°, there will be a step change on the output, but after this first time the output will change smoothly each time the wind passes through 360°. (Similarly, the first time the wind veers from 539° to 180°, there will be a step change, after which the output will change smoothly).

NOTE: Values given for guidance, considering a clockwise spin in Wind Direction

Output	Voltage 0 to 5V	Voltage $\pm 2.5V$	Voltage $\pm 5.0V$	Current 4 - 20 mA	Current 0 - 20 mA
360°					
0°	0.00	- 2.50	-5.0	4.00	0.00
180°	2.50	0.00	0	12.00	10.00
359.9°	5.00	+2.50	+5.0	20.00	20.00

Output	Voltage 0 to 5V	Voltage ± 2.5V	Voltage ± 5.0V	Current 4 - 20 mA	Current 0 - 20 mA
540° wraparound					
0°	0.00	-2.50	-5.0	4.00	0.00
180°	1.67	-0.83	-1.66	9.33	6.67
360°	3.33	+0.83	+1.66	14.67	13.33
539.9°	5.00	+2.50	+5.0	20.00	20.00

9.7. Speed of Sound and Sonic Temperature

Scaling for Speed of Sound and Sonic Temperature (Instrument Software version 2329-110 onwards) is as follows:-

Sonic Temp (Deg C)	-40	-30	-20	-10	0	10	20	30	40	50	60	70
SOS (m/s)	300.00	306.36	312.73	319.09	325.45	331.82	338.18	344.55	350.91	357.27	363.64	370.00
+/-5V	-5.00	-4.09	-3.18	-2.27	-1.36	-0.45	0.45	1.36	2.27	3.18	4.09	5.00
0-5V	0.00	0.45	0.91	1.36	1.82	2.27	2.73	3.18	3.64	4.09	4.55	5.00
+/-2.5	-2.50	-2.05	-1.59	-1.14	-0.68	-0.23	0.23	0.68	1.14	1.59	2.05	2.50
4-20mA	4.00	5.45	6.91	8.36	9.82	11.27	12.73	14.18	15.64	17.09	18.55	20.00
0-20mA	0.00	1.82	3.64	5.45	7.27	9.09	10.91	12.73	14.55	16.36	18.18	20.00

9.8. Status

If an output is configured for Status reporting then example levels will be as follows for good signal high, bad (error) signal low depending on output type. High/Low table contents will be reversed if good signal low, bad signal high is used.

Good Signal status code (high)	+5V	+2.5V	+5v	20mA	20mA
Error Signal Status Code (low)	0V	-2.5V	-5V	0mA	4mA

10. CONFIGURING

It is strongly recommended that **WIND** software (available free from the Gill website www.gill.co.uk) is used to configure the WindMaster.

A less preferred option for configuring is using a terminal emulation package, using command codes.

These are both described in the sections below.

Note Certain combinations of output rate, baud rate and message type may be unsupported.

10.1. WIND software

Download the **WIND** software from the Gill website www.gill.co.uk.

Assuming the WindMaster has been correctly connected to the PC and a Power Supply, the opening menu will show the WindMaster in Measurement mode. A short Start message will be displayed, followed by continuous wind information displayed - the default setting being **Polar**, with the unit of measure **Metres per second** (m/s).

If a message similar to the one below is displayed, click **Tools** and **Synch Comms** in the tool bar and the system will be synchronised and correct data displayed.

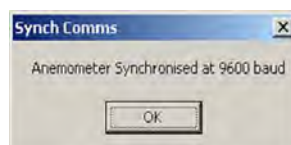
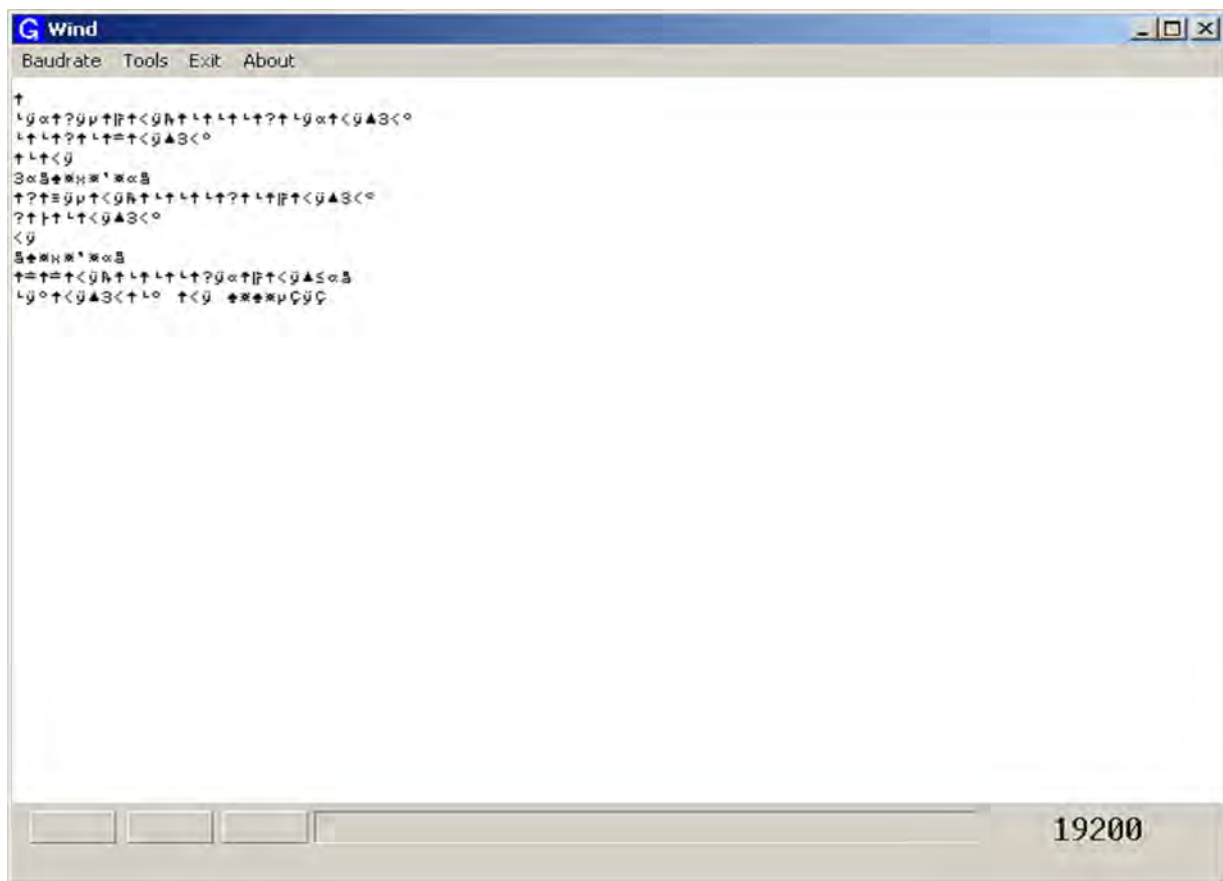

If after Synch Comms there is still a problem with start up, switch power to anemometer off and then on again and repeat procedure.

The unit is set to factory default 1 Hz output and in Polar mode. A typical message format after Synchronising Comms is shown below:

```
WindMaster Pro 32Hz (SS) Gill Instruments Ltd
2329-110
RS232 (AUTO)
CHECKSUM ROM:9B50 9B50 *PASS*
CHECKSUM FAC:07BC 07BC *PASS*
CHECKSUM ENG:1E58 1E58 *PASS*
CHECKSUM CAL:3891 3891 *PASS*
00,061,000.12,+000.06,M,+345.83,+023.77,00,*0D
00,061,000.14,+000.05,M,+345.87,+023.83,00,*07
00,064,000.13,+000.05,M,+345.87,+023.83,00,*05
00,065,000.12,+000.06,M,+345.89,+023.87,00,*0C
00,062,000.13,+000.06,M,+345.83,+023.77,00,*0F
00,067,000.13,+000.06,M,+345.86,+023.82,00,*05
00,067,000.15,+000.05,M,+345.89,+023.87,00,*0A
00,068,000.13,+000.05,M,+345.78,+023.68,00,*0C
00,073,000.13,+000.06,M,+345.84,+023.78,00,*07
```

If you need to review your instrument settings click **Tools** and **Report config** in the tool bar. When selected a similar message to that below will be displayed.



To change the WindMaster configuration click **Tools** and **Wizard** in the tool bar

Typical screens are shown below. The Customer is able to adjust all the settings as required taking into account the options selected at time of order (eg Analogue inputs and PRT).

Anemometer Wizard

Message Output Format	M2 Polar
Baud Rate	19200
Output Rate	P1 1 Hz
Message Terminator	<cr><lf>
Measurement Units	m/s

Alignment	North to spar
Averaging (0 = Off)	0
Resolution	Normal resolution
Minimum direction Resolution	50

Anemometer Wizard

SOS/Sonic Temp Display	SOS & Sonic Temp
Display Analogue Inputs	OFF
Analogue Output Mode	0v to 5V
PRT setting	OFF

Unit Identifier	Q
Power on Message	Display Power On Message
<input checked="" type="checkbox"/> Retries Enabled	
<input type="checkbox"/> Instantaneous Sampling	
<input checked="" type="checkbox"/> Calibration Enabled	
ASCII Format	Fixed Field

DAC Channel 1	U output	5m/s
DAC Channel 2	V output	5m/s
DAC Channel 3	W output	5m/s
DAC Channel 4	Status	Good signal high, bad
<input checked="" type="checkbox"/> Rolling Average for Velocity Fields		
Rolling Average Depth	5	

Next > Cancel

When the changes are complete the Wizard will display a confirmation of the changes with all changes shown in red, this may be printed as a hard copy if required. Click next and the WindMaster will be re-configured and will return to measurement mode.

Anemometer Wizard

THE FOLLOWING FIELDS HAVE CHANGED

Output Message Format : M1 UV(W)
Output Message Format : M2 Polar

THE NEW CONFIGURATION IN FULL

==== DETAILS OF DETECTED ANEMOMETER =====

— SW VERSION —
Anemometer Firmware Version: 2329-110

— HW DETAILS OF ANEMOMETER —
Detected Anemometer Class : WindMaster Pro 32Hz (SS)
Number of AXIS on this unit : 3
ADC resolution of attached unit : 14
DAC resolution of attached unit : 14
Number of ADC channels : 4
Number of DAC channels : 4
Hardware for PRT : FITTED
Maximum sampling rate : (9) P9 32 Hz

— USER CONFIGURATION OF ANEMOMETER —

Baud Rate : 19200
Output Message Format : M1 UV(W)
Output Message Format : M2 Polar
Output Message Velocity Units : m/s
Output Message Terminator : <cr><lf>
Retries : ON
Instantaneous Sampling : OFF
Factory Calibration : ON
Physical Communications : Auto

10.2. Configuring using HyperTerminal

Note – Other terminal emulators can be used to configure the WindMaster in a very similar way.

Setting up

1. Decide on an available Com port that you want to use (Usually Com1).
2. Run Hypertrm.exe (Typically accessed via Start → Programs → Accessories → Communications → Hyperterminal)
3. Create a New Connection (File → New Connection)
4. Enter a Name (eg WindMaster).
5. Change 'Connect Using' to 'Direct to Com 1' (or other Com port as required)
6. Adjust the Port settings to match WindMaster settings. WindMaster default settings are :

Bits per second 19200	Data bits 8	Parity None
Stop bits 1	Flow Control (Handshaking) None	

Assuming the WindMaster has been correctly connected to the PC and a Power Supply, the opening menu will show the WindMaster in **Measurement mode** and scroll continuous wind information data.

Entering Configuration mode

From Continuous mode

From Polled mode

where N is the Unit identifier (a letter between A and Z)

The WindMaster responds with a CONFIGURATION MODE message, stops reporting wind measurements, and waits for a command (as detailed below).

Returning to Measurement mode

The WindMaster responds with wind measurements immediately when in Continuous mode, or on receipt of a Poll signal when in Polled mode.

This will be followed by a checksum test and then continuous wind information is displayed in the example as follows (polar, continuous, all options on).

RS232 (AUTO)

```
CHECKSUM ROM:1020 1020 *PASS*
CHECKSUM FAC:0947 0947 *PASS*
CHECKSUM ENG:1E0B 1E0B *PASS*
CHECKSUM CAL:3891 3891 *PASS*
```

```
00, 118.1, 000.384, -000.992, M, +344.91, +022.19, 00, +2.4181, +2.4187, +2.4162, +2.4175, -50.00C, #71
00, 083.7, 000.686, -001.240, M, +345.96, +023.99, 00, +2.4181, +2.4187, +2.4162, +2.4175, -50.00C, #79
00, 086.4, 000.743, -001.273, M, +346.02, +024.09, 00, +2.4181, +2.4187, +2.4162, +2.4175, -50.00C, #77
00, 105.7, 000.447, -000.988, M, +346.09, +024.21, 00, +2.4181, +2.4187, +2.4162, +2.4175, -50.00C, #76
00, 086.6, 000.659, -001.124, M, +346.07, +024.18, 00, +2.4181, +2.4187, +2.4162, +2.4175, -50.00C, #78
00, 086.5, 000.474, -000.658, M, +346.03, +024.11, 00, +2.4181, +2.4187, +2.4162, +2.4175, -50.00C, #75
00, 098.0, 000.470, -000.897, M, +346.03, +024.11, 00, +2.4181, +2.4187, +2.4162, +2.4175, -50.00C, #7E
00, 098.5, 000.421, -000.997, M, +346.09, +024.21, 00, +2.4181, +2.4187, +2.4162, +2.4175, -50.00C, #7F
00, 096.0, 000.339, -000.839, M, +346.11, +024.25, 00, +2.4181, +2.4187, +2.4162, +2.4175, -50.00C, #72
00, 106.5, 000.259, -000.764, M, +346.19, +024.38, 00, +2.4181, +2.4187, +2.4162, +2.4175, -50.00C, #7A
00, 095.6, 000.394, -001.061, M, +346.13, +024.28, 00, +2.4181, +2.4187, +2.4162, +2.4175, -50.00C, #7B
00, 118.6, 000.335, -000.982, M, +346.04, +024.13, 00, +2.4181, +2.4187, +2.4162, +2.4175, -50.00C, #77
00, 118.4, 000.399, -000.741, M, +345.99, +024.04, 00, +2.4181, +2.4187, +2.4169, +2.4175, -50.00C, #78
```

Checking the configuration

We recommend that, as a standard procedure, you use this command prior to, and after, changing any settings. It shows the current settings for most of the alterable settings.

The WindMaster responds with the current default settings. These are shown below:

We suggest you note down the settings, so that you can easily return to them.

Return to measurement mode

Settings and how to change them are explained in the following section.

Changing settings

To change a setting, refer to the sections below, and enter the command of the new setting required, followed by **ENTER**. If successful, the new setting will be sent back as a message by the WindMaster.

For example, to change the message format to UVW, Continuous, enter **M 1 ENTER**

The WindMaster will reply **M1**. When the unit is returned to the Measurement mode, it will be in UVW, Continuous format.

Note : The factory-set (default) settings are shown in bold in the following sections.

Command List

COMMAND	USER
A	SOS/Sonic Temp Output
B	Baud rate
C	Analogue angle wrapping
D	Diagnostic / Config info
E	Set Physical Comms
F	Signal Processing
G	Averaging Settings
H	Power on message
I	Disable/Enable analogue input
J	High/Low Resolution
K	Minimum Direction Velocity
L	Message Terminator
M	Message Format
N	Set Unit ID
O	Set ASCII format
P	Set output rate
Q	MEASUREMENT MODE
R	Not used
S	Analogue output range
T	Analogue output type & Config
U	Select Units
V	PRT output ON/OFF
W	Not Used
X	Axis Alignment
Y	Not Used
Z	Not used
*	INTERACTIVE MODE

Where the command is a single parameter command the notation is Dx, for example if the parameter x = 2 then in interactive mode the user would type "D2".

Where the Command is dual parameter e.g. Fx y, then x selects the parameter and y turns it on or off (Fx<space>y).

Typing just the command letter will cause the current settings to be output.

Warning: Certain combinations of output rate, baud rate and message type may be unsupported.

Ax – Select SOS/Sonic Temp output

- | | |
|---|----------------|
| 1 | Neither |
| 2 | SOS |
| 3 | Sonic Temp |
| 4 | Both |

The SOS and/or Sonic Temp are displayed after the UNITS and before the status byte, the SOS is always in m/s and the Sonic Temp is always in deg C.

Bx – Set Baud rate

- | | |
|---|--------------|
| 1 | 2400 |
| 2 | 4800 |
| 3 | 9600 |
| 4 | 19200 |
| 5 | 38400 |
| 6 | 57600 |

If a request is sent to change the Baud rate, before it changes it must be confirmed by entering **B** **ENTER** at the new Baud rate.

eg. If set to B3 (9600 baud), to change to B5 (38400 baud), enter **B** **5** **ENTER** , change host terminal to 38400 baud, and confirm by entering **B** **ENTER**.

NOTE: a random echo may be generated after the B5 confirmation

Certain combinations of output rate, baud rate and message type may be unsupported.

Cx – Analogue output polar direction wrapping

- | | |
|---|---|
| 1 | 540 degree wraparound on analogue output |
| 2 | 360 degree wraparound on analogue output |

Dx – Diagnostic and configuration information

- | | |
|---|----------------------------------|
| 1 | Request serial number |
| 2 | Request SW version |
| 3 | Request current configuration |
| 4 | - |
| 5 | - |
| 6 | - |
| 7 | Report DAC channel configuration |

Examples of Diagnostic information are as follows:

Request Serial Number

D1

Y000017

Request SW Version

D2

2329-110

Request Current Configuration

D3

M2,U1,O1,L1,P1,B4,H1,NQ,E1,T1,S1,C2,A1,I1,J1,V1,X1,G0,K50

Report DAC Channel Configuration.

D7

DAC CHAN 01, MODE 05, CONFIG 02

DAC CHAN 02, MODE 09, CONFIG 01

DAC CHAN 03, MODE 04, CONFIG 01

DAC CHAN 04, MODE 08, CONFIG 01

Where:-

Mode 01 = DAC Channel Off.

Mode 02 = U Magnitude Output.

Mode 03 = V Magnitude Output.

Mode 04 = W Magnitude Output.

Mode 05 = Polar Angle Output.

Mode 08 = Status (Good/Bad).

Mode 09 = Polar Magnitude Output.

and Configuration code for Mode 08 equates to good/bad status setting.

Config 01 = Good is high output level, Bad is low level.

Config 02 = Good is low output level, Bad is high level.

and Configuration codes for Modes 02, 03, 04, and 09 equate to scale setting:-

Config 01 = 5m/s

to

Config 08 = 120m/s

and Configuration code for Mode 5 equates to angle wrapping where:-

Config 01 = 540 degree wraparound.

Config 02 = 360 degree wraparound.

Ex Set Physical Communications

1	AUTO
2	485
3	232

It is recommended to leave the unit in AUTO mode. This can also be overridden from RS232 to RS422/485 by linking the comms line to V+ for RS232 or to 0V for RS422/485. See section 6.5 to 6.9.

If a unit is set for E3 and required to be set back to E1 then with a HyperTerminal connection established go into Configuration Mode, Type E1 and Press Enter. Then Type E and Press Enter. Type Q and press Enter to go back into measurement mode.

Fxy Signal Processing

Signal	x	Space	y
Retries Off	1		0
Retries On	1		1
Instantaneous Sampling Off	2		0
Instantaneous Sampling On	2		1
Calibration Off	3		0
Calibration On	3		1

Gx to Gxxxx – Controls averaging setting (Note, does not apply to Analogue Inputs)

0	Averaging disabled
1-3600	Averaging enabled (time in seconds)

The unit can be used to average readings over long periods of time (up to 3600 seconds). When the G command is used the unit is automatically switched to P1 mode (1Hz) and will output at the set number of seconds, it will not output any data in between readings so for long averaging periods the unit will appear to be inactive. If G is set to zero then averaging settings will be disabled.

While averaging is active the Px command is disabled.

Hx – Enable/Disable power on message

1	Power on message enabled
2	Power on message disabled

If the power up message is On, then a message similar to that below is output, whenever the unit goes into Measurement mode (i.e. when power is first applied to the unit, or the unit returns to Measurement mode from Configuration mode).

WindMaster Pro 32Hz (SS) Gill Instruments Ltd

2329-110

RS232 (AUTO)

CHECKSUM ROM:9B50 9B50 *PASS*

CHECKSUM FAC:07BC 07BC *PASS*

CHECKSUM ENG:1E58 1E58 *PASS*

CHECKSUM CAL:3891 3891 *PASS*

If any of these checksums fail, the word PASS will be replaced by FAIL and the unit will use its default settings. If the checksum repeatedly fails after power on – contact your supplier.

Ix – Enable/Disable analogue input message

1	Analogue input data off
2	Analogue input data on
3	Analogue inputs set for 2 Differential Mode pairs

Jx – Set the unit Resolution

1	Select Normal Resolution (UVW, 2 decimal point readings)
2	Select High Resolution (UVW, 3 decimal point readings)

J2 High resolution is applicable to Wind Speed and Wind direction for Metres/sec setting only.

Kxx to Kxxxx Set Minimum direction velocity

This allows the minimum wind velocity to be set at which display of the direction is enabled in thousandth of a metre per second. The default is 50, which means that any wind magnitude <0.05m/s will have the wind direction omitted in polar mode. The maximum value allowed for this is 5000, or 5m/s.

50	Minimum direction velocity
0 to 5000	Select minimum direction velocity (in 0.001m/s steps)

Lx – Message Terminator

- | | |
|---|----------|
| 1 | <CR><LF> |
| 2 | <CR> |

Mx – Message Format

- | | |
|----|----------------------|
| 1 | UVW |
| 2 | Polar |
| 3 | UVW Polled |
| 4 | Polar Polled |
| 7 | Binary, Polar, Short |
| 8 | Binary, UVW, Short |
| 9 | Binary, Polar, Long |
| 10 | Binary, UVW, Long |

Nx – Set unit ID

Sets the unit ID displayed at the start of all GILL communications strings

Set **Q (default)**, ...from A to Z Command N<Q>

Ox – Set ASCII output format

- | | |
|---|--|
| 1 | Comma Separated Variable (CSV) format |
| 2 | Fixed field |

Example string for CSV data changing to an error status code condition.

- Q,335.3,001.261,-001.282,M,+345.41,+023.05,00,+2.4181,+2.4181,+2.4162,+2.4175,-50.00C,□78
- Q,,,,M,,,07,+2.4181,+2.4187,+2.4162,+2.4175,-50.00C,□72

Example string for Fixed Field data changing to an error status code condition.

- Q,251.7,000.860,-000.401,M,+346.43,+024.80,00,+2.4181,+2.4187,+2.4169,+2.4175,-50.00C,□7F
- Q,999.9,999.999,+999.999,M,+999.99,+999.99,07,+2.4181,+2.4187,+2.4169,+2.4181,-50.00C,□77

Px – Set output rate

Note: the P9 setting is an option on the WindMaster unit, which must be specified at the time of ordering.

- | | |
|----|-------------------------------------|
| 1 | Rate is 1 Hz (20Hz Sampling) |
| 2 | Rate is 2 Hz (20Hz Sampling) |
| 3 | Rate is 4 Hz (20Hz Sampling) |
| 4 | Rate is 5 Hz (20Hz Sampling) |
| 5 | Rate is 8 Hz (32Hz Sampling) |
| 6 | Rate is 10 Hz (20Hz Sampling) |
| 7 | Rate is 16 Hz (32Hz Sampling) |
| 8 | Rate is 20 Hz (20Hz Sampling) |
| 9 | Rate is 32 Hz (32Hz Sampling) |
| 20 | Rate is ¼ Hz |
| 21 | Rate is ½ Hz |

Sx – Analogue output range

This sets the velocity scaling for the analogue output. (see also Para 9.5).

- | | |
|---|---------------------------|
| 1 | Full range is 5m/s |
| 2 | Full range is 10m/s |
| 3 | Full range is 20m/s |
| 4 | Full range is 30m/s |
| 5 | Full range is 40m/s |
| 6 | Full range is 50m/s |
| 7 | Full range is 60m/s |
| 8 | Full range is 120m/s |

Tx – Set analogue output type

Use Gill Wind Software to set required ranges

- | | |
|---|-----------------------|
| 1 | 0V to 5V range |
| 2 | -2.5V to 2.5V range |
| 3 | 4mA to 20mA range |
| 4 | -5V to 5V range |
| 5 | 0mA to 20mA range |

Ux – Set units

- | | |
|---|------------|
| 1 | m/s |
| 2 | Knots |
| 3 | MPH |
| 4 | KPH |
| 5 | FPM |

Vx – Enable/Disable PRT

- | | |
|---|------------|
| 1 | OFF |
| 2 | ON |

Note: PRT not an Option fitted to the WindMaster.

Xx – Axis Alignment

- | | |
|---|---|
| 1 | Align U Axis to unit North Spar (See Fig 2). |
| 2 | Align U to the top axis transducer 1 |
| 3 | Same as X1 but inverted for upside down operation |
| 4 | Same as X2 but inverted for upside down operation |

11. MAINTENANCE & FAULT-FINDING

11.1. Cleaning

If there is any build up of deposit on the unit, it should be gently cleaned with a cloth moistened with water and soft detergent. Solvents should not be used, and care should be taken to avoid scratching any surfaces. The unit must be allowed to defrost naturally after being exposed to snow or icy conditions, do NOT attempt to remove ice or snow with a tool.

11.2. Servicing

There are no moving parts or user-serviceable parts requiring routine maintenance.

Opening the unit or breaking the security seal will void the warranty and the calibration.

In the event of failure, prior to returning the unit to your authorised Gill distributor, it is recommended that :

1. All cables and connectors are checked for continuity, bad contacts, corrosion etc.
2. A bench test is carried out as described in Section 12.1.
3. You contact your supplier for advice

11.3. Fault-finding

Symptom	Solution
No output	<p>Check DC power to WindMaster, cable and connections.</p> <p>Check comms settings of WindMaster (<i>as detailed in Section 10</i>) and host system match, including correct Com port. Try using Gill Wind Software/Tools/Synch Comms</p> <p>Check unit is in Continuous mode</p> <p>Check that in-line communication devices are wired correctly.</p> <p>NOTE: It is usual for Anemometer TX to be connected to converter device RX</p>
Corrupted output	<p>Check comms settings of WindMaster and host system match.</p> <p>Try using Gill Wind Software/Tools/Synch Comms</p> <p>Try a slower baud rate.</p> <p>Check cable lengths and type of cable.</p>
One way communication	<p>Check WindMaster and host system are both set to the same protocol RS232, RS422, or RS485.</p> <p>Check wiring is in accordance with the manual.</p>
Failed / Incorrect WindMaster output, data invalid flag	<p>Check that transducer path is not blocked</p>

11.4. Status (error) codes

The Status code is sent as part of each wind measurement message.

Code	Status	Condition
00	OK	Functioning correctly
01	Sample failure	Insufficient samples in average period from transducer pair 1
02	Sample Failure	Insufficient samples in average period from transducer pair 2
03	Sample Failure	Insufficient samples in average period from transducer pair 3
04	Sample Failure	Insufficient samples in average period from transducer pairs 1,2
05	Sample Failure	Insufficient samples in average period from transducer pairs 1,3
06	Sample Failure	Insufficient samples in average period from transducer pairs 2,3
07	Sample Failure	Insufficient samples in average period from all transducer pairs
08	NVM Error	NVM Checksum failed
09	ROM Error	ROM checksum failed
0A	System gain at Maximum	Results OK, but marginal operation
0B	Retries	Retries used

11.5. Returning unit

If the unit has to be returned, it should be carefully packed in the original packaging and returned to your authorised Gill distributor, with a full description of the fault condition.

12. TESTS

12.1. Bench test

1. Couple the WindMaster to the host system and power supply, using a known working test cable.
2. Check that the unit is correctly configured (*see Section 10*).
3. Check for normal output data, and that the Status Code is OK – 00.
4. If the status code is other than 00 or 0A, refer to Section 11.5 Status (error) codes.
5. Use an office fan or similar to check that the unit is sensing wind, turning the unit to simulate changing wind direction and to check that all three axes are functioning.
6. Note that this is a quick functional test. There are no calibration adjustments. *See 12.2.*

Note: Refer to Dx – diagnostic and configuration information for further self tests

12.2. Calibration

Note - There are no in-use calibration adjustments; the unit is designed NOT to require re-calibration within its lifetime.

Standard calibration

Accuracy at 12 m/s Wind speed 1.5% RMS Direction 2°

Certified calibration

The unit can be Wind tunnel calibrated in accordance with ISO 16622 with traceability to national standards. This should be specified when ordering, or the unit can be returned to Gill Instruments for retrospective calibration.

Accuracy at 12 m/s Wind speed 1% RMS Direction 0.5°

13. APPENDICES

13.1. Guarantee

For terms of guarantee contact your supplier.

Warranty is void if the red security seal covering base nuts is damaged or broken, or the transducer caps have been damaged.

13.2 ELECTRICAL CONFORMITY

EC DECLARATION OF CONFORMITY ACCORDING TO COUNCIL DIRECTIVE 2004/108/EC



We, Gill Instruments Ltd., declare our under sole responsibility that the products:

WindMaster (1590-PK-020 + options)
WindMaster Pro (1561-PK-020 + options).

Manufactured by: Gill Instruments Ltd
Saltmarsh Park
67 Gosport Street
Lymington, SO41 9EG

to which this declaration relates, are in conformity with the protection requirements of Council Directive 2004/108/EC on the approximation of the laws relating to electromagnetic compatibility.

This Declaration of Conformity is based upon compliance of the product with the following harmonized standards:

Emissions EN 61326
Immunity EN 61326

A handwritten signature in black ink that reads "A.C.R. Stickland".

Signed by:

A.C.R. Stickland – Director

Date of issue: 27/06/2006

Place of issue: Gill Instruments Ltd
Saltmarsh Park
67 Gosport Street
Lymington, SO41 9EG

